

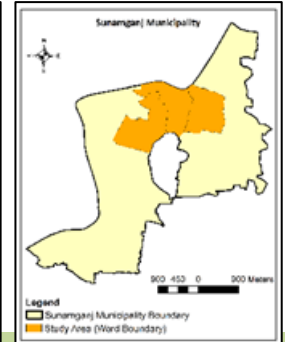

Earthquake Contingency Plan for Ward 4, Sunamganj Municipality: Volume 2

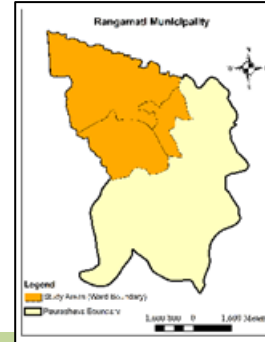

BUET-Japan Institute of Disaster Prevention and Urban Safety (BUET-JIDPUS)
Department of Urban and Regional Planning
Department of Civil Engineering
Bangladesh University of Engineering and Technology (BUET),
Dhaka-1000, Bangladesh.

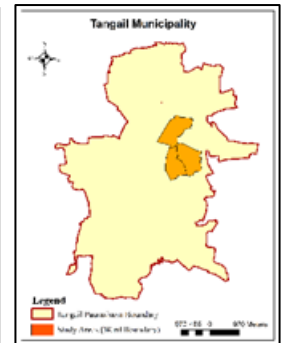
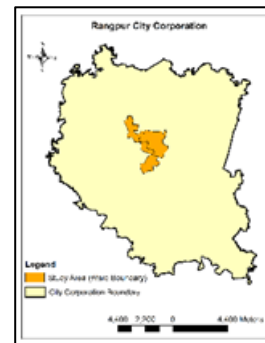

Earthquake Risk Assessment for Developing Contingency Plans, Training Modules and Awareness Materials for Rangpur City Corporation and Tangail, Rangamati and Sunamganj Pourashavas



BUET-Japan Institute of Disaster Prevention and Urban Safety (BUET-JIDPUS)
Department of Urban and Regional Planning
Department of Civil Engineering
Bangladesh University of Engineering and Technology (BUET),
Dhaka-1000, Bangladesh.

Project Team Members

Faculty:

- Prof. Dr. A. F. M. Saiful Amin, Director, BUET-JIDPUS, Professor, Dept. of Civil Engineering, BUET
- Prof. Dr. Raquib Ahsan, Professor, Dept. of Civil Engineering, BUET
- Prof. Dr. Ishrat Islam, Professor, Dept. of Urban and Regional Planning, BUET
- Prof. Dr. Mohammad Shakil Akther, Professor, Dept. of Urban and Regional Planning, BUET
- Ms. Uttama Barua, Assistant Professor, Dept. of Urban and Regional Planning, BUET
- Ms. Tasnim Tarannum, Assistant Professor, BUET-JIDPUS
- Ms. Shamontee Aziz, Assistant Professor, BUET-JIDPUS
- Ms. Sadia Afroj, Lecturer, Dept. of Urban and Regional Planning, BUET

Research Assistant:

- Ms. Shegufta Zahan, Dept. of Civil Engineering, BUET
- Ms. Meher Afjun Faria, Dept. of Urban and Regional Planning, BUET
- Ms. Madiha Chowdhury, Dept. of Urban and Regional Planning, BUET

Officer and Technical Personnel:

- Md. Samsur Rahman, BUET-JIDPUS
- Md. Jasim, BUET-JIDPUS
- Mr. Azader Rahman, BUET-JIDPUS
- Md. Haroonor Rashid, BUET-JIDPUS

ACKNOWLEDGEMENT

The project, “Earthquake Risk Assessment for Developing Contingency Plans, Training Modules and Awareness Materials for Rangpur City Corporation; and Tangail, Rangamati and Sunamganj Pourashavas”, is a project of and funded by National Resilience Programme (NRP), Department of Disaster Management (DDM) Part under the Ministry of Disaster Management and Relief (MoDMR). The cooperation extended by the MoDMR, DDM and UNDP for this project is highly appreciated and acknowledged by the research team.

The members of the research team express their gratitude to Sunamganj Pourashava and Ward Office of Ward No. 4 of Sunamganj Pourashava for offering the necessary support to arrange meetings and to communicate with various stakeholders.

Last but not the least, the project team is cordially thankful to the local people and volunteers of the study area for their kind cooperation and help during the training sessions, exploration of inventories, and field works of the research.

EXECUTIVE SUMMARY

Bangladesh is particularly vulnerable to earthquakes due to its geographical location. It lies in a moderately seismic-prone region, and historical evidence points to significant earthquakes within or close to the country. Moreover, rapid urbanization, population growth, migration, and the development of economic activities are also inducing an impetuous increase in vulnerability (CDMP, 2014). According to the Seismic Zoning Map of BNBC 2020, Bangladesh comprises four seismic zones, where Sunamganj belongs to Seismic Zone 4 with a Seismic Coefficient value of 0.36g.

Sunamganj is located at a vulnerable seismic zone near the Dauki fault. Sunamganj faced a severe earthquake of magnitude 7.6 in 1918 originating at Sreemangal upazila of the Moulvibazar district. Also the district was severely damaged by the earthquake incidents occurred in 1923 and 1997.

This project has been undertaken to develop a community-based earthquake risk reduction and management plan for twelve wards of Rangpur City Corporation, Tangail Pourashava, Sunamganj Pourashava, and Rangamati Pourashava. For this purpose, the research team has prepared ward-based contingency plans for the above-mentioned study areas. The tasks include assessment of seismic risk, assessment of the building and socio-economic vulnerability, and finally, preparation of earthquake contingency plan. Accordingly, the objectives of this report are:

- To assess the seismic exposure of ward-4 of Sunamganj Pourashava,
- To assess the structural and socio-economic vulnerabilities of the area, and
- To formulate a community-based earthquake contingency plan for the area.

The project in Sunamganj was initiated through an inauguration workshop at Sunamganj Pourashava on May 20, 2019. For this research, both primary and secondary data were collected. Engineering surveys and social surveys were conducted to understand the soil characteristics, physical vulnerability of structures, and socio-economic context of the community. In addition, secondary data on land

use were collected from the Sunamganj Pourashava office. The collected GIS database was not updated and usable for this project due to their chronic gap and absence of required information. Therefore, updating proceeded through two stages: 1) updating GIS spatial data through satellite image processing, and 2) field verification, updating spatial and non-spatial data required for the project. To conduct the field verification, a checklist was prepared in “KoboToolbox” interface to collect the non-spatial information, and a training program was arranged to enhance the capacity of the local surveyors. Data on land use, building floor use, building type and storey, road layout with width were collected in this stage that was used to update the final GIS database.

The study area, ward-4 of Sunamganj Pourashava, is located at Sunamganj district in Sylhet division. For the convenience of data collection and planning, the study area was divided into six clusters. The population of Ward No 4 is 7522. The majority of the population (28.9%) belongs to the 30-49 years age group. The literacy rate of the study area is 79.7%. The major land use of ward-4 is residential. The structures serving health facilities (0.91%) are very negligible to be counted.

To assess the preliminary vulnerability of the buildings in the study area, Level 1 survey of Rapid Visual Screening (RVS) suggested by Federal Emergency Management Agency (FEMA), USA, 2017 edition was adopted. In Ward-4, 108 pucca buildings were assessed by the RVS method. The sample size was determined based on the proportional distribution of pucca buildings in the wards of Sunamganj Pourashava, considering institutional, administrative buildings, and private-owned buildings. Some seismic factors, e.g., vertical irregularity, overhang, clear distance from the surrounding building, etc. were taken into consideration in this method. The preliminary assessment aims to get a basic overview of the existing structural condition of the buildings located in the study area. After sample size determination, cluster-wise base maps indicating the sample buildings were prepared in ArcGIS. The form of FEMA for RVS (Level 1) survey was prepared in “KoBo Toolbox,” and data on structural vulnerability was collected through the participation of local engineers and volunteers.

A household questionnaire survey was conducted to collect data for social vulnerability assessment and earthquake contingency planning for the study area. Total 66 households from 66 residential structures were selected as sample size. Here, all four or higher storied buildings were considered. The remaining sample buildings were selected from two categories: three or less storied, and kutcha or semi pucca residential buildings. These two types of buildings were taken into the sample, maintaining their actual proportion in each cluster to ensure proper representation of all existing categories of structures in a cluster. The proportion of owner and tenant was also considered since the consent of building owners will be required in the future process of earthquake preparedness. The proportion for household distribution of owners and tenants within the determined sample size was taken as 70% and 30% accordingly. All residential buildings within the four or higher storey category were also surveyed for building vulnerability assessment. A checklist survey was conducted for potential disaster shelters and emergency health facilities for contingency planning.

In order to determine the seismic hazard of ward no. 4, two Standard Penetration Tests have been done. From these, it has been observed the soil profile of borehole 1 shows five different layers of soil where the N value up to 10.5m is less than 5. Moreover, a layer of organic clay with peat was located from 7.5m to 9m. The SPT-N value increases beyond 10.5 and reaches a maximum of 28 at 16.5m. As the depth increases further, the N value remains within 20 to 24, with an exception at 24m where the value becomes 27. On the other hand, the soil profile of bore hole 2 also shows five layers of soil. However, no organic soil was detected in this borehole. Up to 7.5m, the SPT-N value remains below 5 resulting in low soil strength. The SPT-N value increases beyond this depth with occasional fluctuation and reaches at a value higher than 20 (N=24) at 18m. At the last layer of medium dense sandy silt, the N values stay mostly steady among 18-24. However, the maximum value of 26 is obtained at 27 m. According to the soil classification (FEMA 2017), the soil class is D. From the microtremor analysis, the natural frequency of the soil is found to be around 4.5 Hz, and the shear wave velocity is around 129.05 m/s (Bore hole-1) and 130.78 m/s (Bore hole-2). These data will be used further to determine index and engineering properties of soil along with the determination of liquefaction potential.

Among the 108 buildings selected for the preliminary vulnerability assessment, all the institutional (educational facilities, religious facilities, and health facilities) and administrative buildings (government offices) of ward no. 4 are included. Along with this, all buildings which are four stories or higher were selected as their structural vulnerability will impact the contingency planning. One to three storey buildings were also surveyed to judge their performance. The number of stories of the surveyed buildings varies among 1 to 8. Among the surveyed buildings, 101 buildings are Concrete Frame with Unreinforced Masonry Infill Walls (C3 as per FEMA classification), 5 buildings are Concrete Shear Wall Building (C2 as per FEMA classification), 1 building is Unreinforced Masonry building (URM as per FEMA classification), and 1 building is Steel Frame Building with Unreinforced Masonry Infill Walls (S5 as per FEMA classification). 8% of the total buildings show severe vertical irregularity, and 8% show moderate vertical irregularity. 8% of the buildings possess plan irregularity. For determining the vulnerability of buildings based on collected data, the RVS score was calculated for each building considering the probability of building collapse and average expected ground shaking levels for the seismicity region. The study area falls within a moderately high seismic zone. According to FEMA, the maximum achievable score for C3 (considering soil class D) is 1.4. Thus, a cut-off score of 1.2 has been selected. The cut-off signifies that if a building has a score below this, it will be vulnerable. It has been observed that 79% of the sample size have a RVS score greater than or equal to 1.2. The remaining 21% has a score below 1.2. And so, this 21% are vulnerable. Based on these results, Detailed Engineering Assessment of a school building that has been chosen for WCC for the corresponding ward is performed. According to the Finite Element Modelling analysis based on the determined core strength and ferro-scanning; also from the results of footing excavation, it was found that to use the structure in the future as a ward coordination center, necessary retrofitting of the inadequate columns need to be done.

Based on data collected from the questionnaire survey of 66 households' statistical analysis was performed to understand the socio-economic context of the area. Gender and age composition, occupation, education level, and physical disability status of total 309 members of 66 households were analyzed to prepare the socio-

economic profile of the study area. Socio-economic survey reveals that around 33% of the population are children and elderly who would require assistance after an earthquake. There is no family with physically challenged members. Around 62% of the respondents are students and housewives. It is interesting to note that only nine percent of the inhabitants of the surveyed households are illiterate. Most of the households have income below 40,000 BDT per month. Among the surveyed respondents, 79% of respondents know about the earthquake vulnerability of their area. They don't have adequate knowledge regarding the actual reasons and are not aware of the precautions that should be taken for earthquake resilience. While the respondents were asked about the earthquake vulnerability of their own buildings, 14% of the respondents considered their buildings to be vulnerable. In addition, only 7 out of 309 household members of the respondents showed their interest in getting involved with the activities of the ward disaster management committee. From a field survey it has been found that 61% of the respondents had previous experiences of earthquake events, while 7.5% of the respondents panicked or did nothing in response to the earthquake. 9.1% of the respondents prefer to go to temporary shelter after an earthquake if necessary; it is seen that the highest number of respondents prefers educational institutions as their first preferred temporary shelter. As their second choice, government institutions were chosen. It has been found that 36% of building owners (15 of 42) are willing to invest money for building strengthening if their buildings have been found vulnerable.

The earthquake contingency plan prepared to reduce the seismic vulnerability of the study area includes temporary shelter planning, emergency health facility planning, Ward Coordination Center planning, and evacuation route planning. First, the demand and supply calculations of the temporary shelters and emergency health facilities were conducted, and later the demand-supply scenario was compared to understand deficiency or surplus. For temporary shelter planning, open spaces and community facility buildings were considered to be used as temporary shelters as per the preference of the respondents of the study area. Among the facility buildings, structurally vulnerable buildings (with RVS score less than 1.2) were excluded. Maps with the location of possible temporary shelters and supply scenarios were shown in the contingency plan. From the demand-supply

comparison, it was found that the supply of temporary shelter in safe facilities is sufficient to accommodate the people requiring disaster shelter. 6126 people can be accommodated in the safe buildings. However, the capacity can be increased if unsafe facility buildings are retrofitted. If the unsafe buildings were retrofitted, they would be able to accommodate 1640 more people to make it sufficient according to the demand scenario.

In the case of emergency health facility planning, a possible number of injured people in the study area were calculated corresponding to different severity levels. The capacity of the health facilities was calculated here for two scenarios. First, only structurally safe health facility buildings were considered. Second, structurally unsafe health facility buildings were taken into account. It has been found that there are no clinics, one diagnostic center, two pharmacies and nine hospitals. Except only five hospital buildings, the rest buildings are structurally safe enough to be used as emergency health facilities. 639 people can be treated there at the time of emergency. If the unsafe building could be retrofitted, a total of 702 people could have been given health service at the time of emergency. Thus, existing facilities are sufficient to meet the demand.

Accessibility of the roads for rescue and rehabilitation were identified considering the road width and blockage size after an earthquake. It was observed that roads less than 8 feet are mainly prone to blockage. It indicates that rescuing from residential buildings, and access to temporary shelters and emergency health facilities will be quite challenging. The single-lane carriageway, which connects this ward with the surrounding wards, will be blocked in at least four locations.

The building of Govt. S M Girls' High School has been proposed for the establishment of WCC in this ward. The institutional setup and management activities of WCC have been proposed, including the criteria of selecting members and their activities at different phases of the earthquake. To ensure proper preparedness at household level, awareness programs, workshops, training, and mock drills should be organized by WDMC to train them about responding during and immediately after an earthquake. A family emergency plan should be developed and practiced regularly. Emergency kits should be kept ready by the households,

which would contain necessary products to sustain after an earthquake, e.g., water, non-perishable food, medicine, flashlight, cash, first aid box, etc.

It should be borne in mind that a contingency plan is neither a standalone document nor a static document. It should be part of an ongoing process integrating activities of different actors. Contingency plan is a collaborative effort, and it must also be linked to the plans, systems or processes of government machinery and non-government partners at all levels – national, regional, and global. It is well understood that an earthquake would cause damage at the regional scale. So, a region-wide community-level contingency plan needs to be prepared. For successful implementation of the contingency plan, this kind of plan needs to be prepared for the other wards of the City Corporation.

TABLE OF CONTENTS

<u>Contents</u>	<u>Page Number</u>
Acknowledgement	i
Executive Summary	ii
List of Figures	xiii
List of Tables	xvi
CHAPTER 1 : INTRODUCTION	1
1.1 Background of the Project and Earthquake Vulnerability of the area	1
1.2 Aim and Objectives of the Project.....	2
1.2.1 Aim of the Project.....	2
1.2.2 Objective of the Project.....	2
1.3 Organization of the Report.....	2
CHAPTER 2 : STUDY AREA PROFILE	4
2.1 Location of the Study Area.....	4
2.2 Existing Land Use of the Study Area.....	4
2.3 Profile of Built Structures in the Study Area.....	5
CHAPTER 3 : SITE Specific Seismic Hazard Assessment	7
3.1 Introduction	7
3.2 Borehole Data (SPT value and Description of Soil)	7
3.3 Microtremor Test.....	10
3.3.1 Result of Microtremor Analysis.....	10
CHAPTER 4 : Building Vulnerability Assessment	12
4.1 Introduction	12
4.2 Preliminary Assessment using Rapid Visual Screening.....	12
4.3 Results and Discussion of Preliminary Vulnerability Assessment	12
CHAPTER 5 : Detailed Engineering Assessment	18
5.1 Introduction	18

5.2	Salient Features and Drawing of the Building	18
5.3	Assessment of As-Built Condition.....	19
5.3.1	Assessment of Concrete Strength	19
5.3.2	Ferro-Scan Test for Reinforcement Identification.....	20
5.3.3	Checking the Foundation	20
5.4	Finite Element Modeling.....	20
5.5	Results	21
CHAPTER 6 : Socio-economic Vulnerability Assessment.....		24
6.1	Introduction.....	24
6.2	General Socio-economic profile of surveyed population	24
6.2.1	Gender and age composition.....	25
6.2.2	Occupation	26
6.2.3	Educational qualification	26
6.2.4	Physically/mentally challenged population	27
6.2.5	Monthly household income.....	27
6.2.6	Building ownership.....	28
6.2.7	Duration of stay in the area.....	28
6.3	Awareness Status and Knowledge of People about Earthquake.....	29
6.3.1	Awareness status and overall knowledge of people.....	29
6.3.2	Source of awareness about earthquake	30
6.3.3	Preferable medium for raising awareness	31
6.4	Peoples' Perception about Earthquake Vulnerability of the Area	31
6.4.1	Peoples' perception regarding earthquake vulnerability of the area from socio-demographic context	32
6.4.2	Peoples' perception regarding earthquake vulnerability of the area with respect to duration of stay.....	33
6.4.3	Reasons behind earthquake vulnerability of the area according to the respondents.....	34
6.5	Peoples' Perception about Earthquake Vulnerability of their Building.....	34
6.5.1	Peoples' perception about earthquake vulnerability of their building with respect to land ownership status and duration of stay.....	35

6.5.2 Reasons behind earthquake vulnerability of buildings according to the respondents.....	35
6.6 People’s Perception Regarding Earthquake Response.....	36
6.6.1 Experience and Response of the Respondents to Earthquake.....	36
6.6.2 People’s perception and preference regarding temporary shelter	37
6.7 People’s Overall Preparation for Earthquake.....	38
6.8 People’s Eagerness to Participate in Disaster Management Activities.....	38
6.8.1 Peoples’ willingness to get involved in disaster management related activities of ward.....	39
6.8.2 Peoples’ willingness to work as a volunteer	39
6.9 Perception of Owners about Investment for Building Strengthening	39
6.9.1 The willingness of the owners to invest in building strengthening with respect to their perception of building vulnerability.....	39
6.9.2 Support required by owners for building strengthening	40
6.10 Perception about Road Widening	40
CHAPTER 7 : CONTINGENCY PLAN FOR EARTHQUAKE IN THE STUDY AREA	41
7.1 Introduction.....	41
7.2 Temporary Shelter Planning	41
7.3 Emergency Health Facility Planning	48
7.4 Evacuation Route Plan	54
7.5 Ward Co-ordination Center.....	61
7.6 Debris Accumulation Point	63
CHAPTER 8 : Implementation and Management of the Contingency Plan.....	65
8.1 Activities of Ward Disaster Management Committee at Different Phases of an Earthquake	68
8.2 Institutional Arrangements for Temporary Shelter Management	71
8.2.1 General Responsibilities of Teams in TSMC	73
8.2.2 Phases for Temporary Shelter Management.....	77
8.3 Institutional Arrangements for Emergency Health Facility.....	79
8.4 Activities of Relief Team.....	80
8.5 Activities of First Aid Team and Rescue Team.....	81

8.6 Institutional Setup of Ward Disaster Response Coordination Group and Center.....	81
8.6.1 General Criteria for Selecting Members of the Sub-Committees.....	82
CHAPTER 9 : Conclusion.....	83
REFERENCES.....	xv
APPENDIX A	xviii
APPENDIX B	xxi
APPENDIX C	

LIST OF FIGURES

Figures	Page Number
Figure 1.1: Proximity of study area to major fault lines.....	2
Figure 1.2: Revised Seismic Zoning of Bangladesh.....	2
Figure 2.1: Location Map of the study area.....	4
Figure 2.2: Map showing land use of the study area.....	5
Figure 2.3: Distribution of structures according to building use.....	6
Figure 3.1: SPT data of Bore Hole 1 of Ward 4.....	8
Figure 3.2: SPT data of Bore Hole 2 of Ward 4.....	9
Figure 3.3: Amplitude Ratio vs Frequency graph of Ward no. 4 of Sunamganj Pourashava.....	10
Figure 4.1 (a): Relations between percentage of buildings and RVS score of Ward 4 for moderately high seismicity.....	14
Figure 4.1 (b): Relations between percentage of buildings and RVS score of ward no 4 for high seismicity.....	14
Figure 4.2: Relations between the percentage of buildings and no. of story of Ward 4.....	15
Figure 4.3: Percentage of Different Building Types.....	16
Figure 4.4: Relations between percentage of buildings and severe vertical irregularity.....	16
Figure 4.5: Relations between percentage of buildings and moderate vertical irregularity.....	17
Figure 4.6: Relations between percentage of buildings and plan irregularity.....	17
Figure 5.1: Core extraction from a column.....	19
Figure 5.2: Footing excavation.....	20
Figure 5.3: 3-D view of the finite element model before analysis.....	22
Figure 5.4: 3-D view of the building in FEM after analysis with reinforcement details.....	22
Figure 5.5: Elevation view to identify overstressed columns along (a) 2-ABCDEFGHIJKLMN (b) 4-ABCDEFGHIJKLMN frames.....	23
Figure 6.1: Distribution of household members according to their occupation.....	26

Figure 6.2: Distribution of household members according to educational qualification	27
Figure 6.3: Distribution of monthly household income of the surveyed household..	28
Figure 6.5: Distribution of households according to their duration of stay in the area	29
Figure 6.6: Sources of knowledge of earthquake of the respondents	30
Figure 6.7: Distribution of household representatives who are aware of the earthquake vulnerability of their area according to educational qualification	33
Figure 6.8: Ranked reasons of earthquake vulnerability of the area according to the respondents.....	34
Figure 6.9: Ranked reasons of earthquake vulnerability of the buildings according to the respondents.....	36
Figure 6.10: Last year when respondents experienced an earthquake	37
Figure 6.11: Distribution of actions that has been taken during earthquake according to the respondents.....	37
Figure 7.1: Location of selected temporary shelter in the study area	44
Figure 7.2: Location of selected temporary shelter in the study area considering safety	45
Figure 7.3: Location of selected emergency health facilities in the study area	49
Figure 7.4: Location of selected emergency health facilities in the study area considering safety	50
Figure 7.5: Road width and accessibility condition.....	56
Figure 7.6: Possible road blockage condition for Scenario 01	57
Figure 7.7: Evacuation Route Map for Scenario 01.....	58
Figure 7.8: Possible road blockage condition for Scenario 02	59
Figure 7.9: Evacuation Route Map for Scenario 02.....	60
Figure 7.10: Location of selected Ward Co-ordination Center.....	62
Figure 7.11: Possible locations of TDRS.....	64
Figure 8.1: The tiers of Disaster Management Committees at local level and the structure of Ward Management Committee.....	67
Figure 8.2: Structure of Temporary Shelter Management Committee (TSMC) and their activity at different phases of an earthquake.....	73

Figure 8.3: Structure of Emergency Health Facility Management Committee (EHFMC) and their activity at different phases of an earthquake 80

LIST OF TABLES

Figures	Page Number
Table 2.1: Distribution of pucca structures according to number of storey.....	5
Table 6.1: Distribution of respondents according to their age group.....	25
Table 6.2: Detail knowledge of respondents about earthquake	29
Table 6.3: Ranked preference for most effective medium for increasing ability and awareness of earthquake risk by the respondents	31
Table 6.4: Distribution of household representatives who answered that they are aware of the earthquake vulnerability of their area according to their age	32
Table 6.5: Distribution of respondents according to their perception regarding earthquake vulnerability of the area and duration of stay.....	33
Table 6.6: Distribution of respondents according to their perception about earthquake vulnerability of their building and their duration of stay.....	35
Table 6.7: Willingness of the owners to invest for strengthening building with respect to their perception about the building being earthquake vulnerable.....	40
Table 7.1: Supply scenario of the possible temporary shelters in the study area considering dry season.....	46
Table 7.2: Supply scenario of the possible temporary shelters in the study area considering rainy season.....	47
Table 7.3: Need of emergency health facilities in the study area	48
Table 7.4: Supply scenario of the possible emergency health facilities in the study area considering dry season.....	51
Table 7.5: Supply scenario of the possible emergency health facilities in the study area considering rainy season.....	52
Table 7.6: Demand-supply comparison of emergency health facilities in the study area	54

CHAPTER 1 : INTRODUCTION

Earthquakes can occur with no prior warning resulting in widespread loss and damage, and adverse effects on economic, social and political sector which can drive the entire nation to disastrous consequences (CDMP, 2014). To mitigate the earthquake risk, proper planning and management are required through investigating the interrelated issues based on earthquake vulnerability assessment.

1.1 Background of the Project and Earthquake Vulnerability of the area

Bangladesh is physically, economically, and socially vulnerable to earthquake (CDMP, 2014). A severe earthquake in this country, anticipated in the near future, will cause a large number of human casualties, huge damages of infrastructures, social and economic loss, etc. (Alam *et al.*, 2008; CDMP, 2009; Ministry of Disaster Management and Relief, 2015). Earthquake risk management planning includes seismic exposure assessment, building and socio-economic vulnerability assessment, and contingency planning. (NORSAR, 2018; Lal *et al.*, 2011; CDMP, 2014; CDMP, 2009).

To ascertain an effective response to severe earthquake events; an organized earthquake risk management planning is necessary at the local level. Realizing this, National Resilience Programme (NRP) under the Ministry of Disaster Management and Relief (MoDMR) of the People's Republic of Bangladesh has taken the initiative to develop a minimum preparedness package for earthquake preparedness for the cities, which are thoroughly described in Annexure A. Activities are implemented in Rangpur City Corporation, and Tangail, Rangamati, and Sunamganj Pourashava. This report contains the earthquake risk management planning of Ward 4 of Sunamganj Pourashava.

Sunamganj is located at a vulnerable seismic zone near the Dauki fault (Figure 1.1). According to the Revised Seismic Zoning Map of BNBC, Sunamganj belongs to Seismic Zone 3 (Figure 1.2).

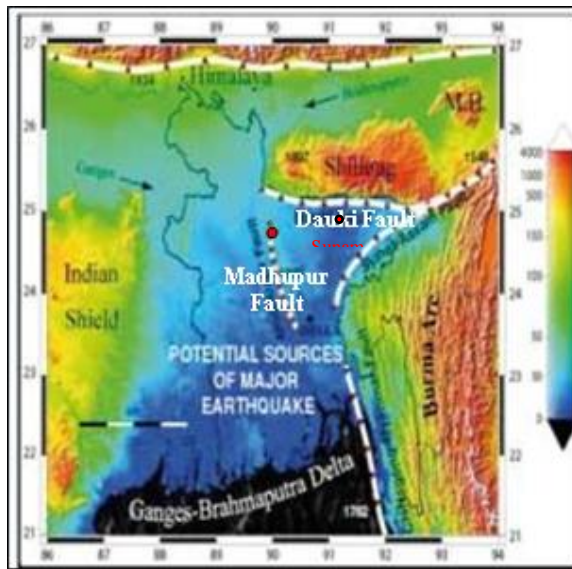

Figure 1.1: Proximity of study area to major fault lines
(Source: Akhter, 2010)



Figure 1.2: Revised Seismic Zoning of Bangladesh
(Source: HBRI, 2015)

1.2 Aim and Objectives of the Project

1.2.1 Aim of the Project

The aim of the assignment is “building earthquake resilient community through vulnerability assessment, capacity and awareness building and promoting safe construction practices”.

1.2.2 Objective of the Project

The objective of the assignment is to formulate community-based earthquake preparedness and management plan in Rangamati Pourashava. The task includes the participation of community and engagement of their intuitions in assessment, planning, capacity, and awareness building.

1.3 Organization of the Report

There are nine chapters in this report. In chapter one, the background and objectives of the research have been discussed. Chapter two focuses on the profile of the study area, including the geographic, demographic, and other characteristics of the study area. Chapter three and four describes the assessment results of seismic exposure and building vulnerability of the study area, respectively. In chapter five, detailed hazard

assessment of a building of this area have been discussed. In chapter six, the socio-economic vulnerability assessment results of the study area have been discussed. Chapter seven includes components of earthquake contingency planning, including temporary shelters, emergency health facilities, evacuation routes, and ward coordination center. Chapter eight discusses the management and implementation strategies of the contingency plan. Finally chapter nine concludes with some future scopes of this contingency plan during and after an earthquake event.

CHAPTER 2 : STUDY AREA PROFILE

Sunamganj Pourashava is situated at Sunamganj district in Sylhet division. It was established in 1983 (BBS, 2011b). The total population is 65,332 with a density of 960 persons per sq. km (BBS, 2011b). Among the 9 Wards of Sunamganj Pourashava, Ward 2, Ward 4 and Ward 5 have been selected as a study area for this project.

2.1 Location of the Study Area

Figure 2.1 shows the location of the study area of Sunamganj Pourashava as well as Ward map of Ward 4.

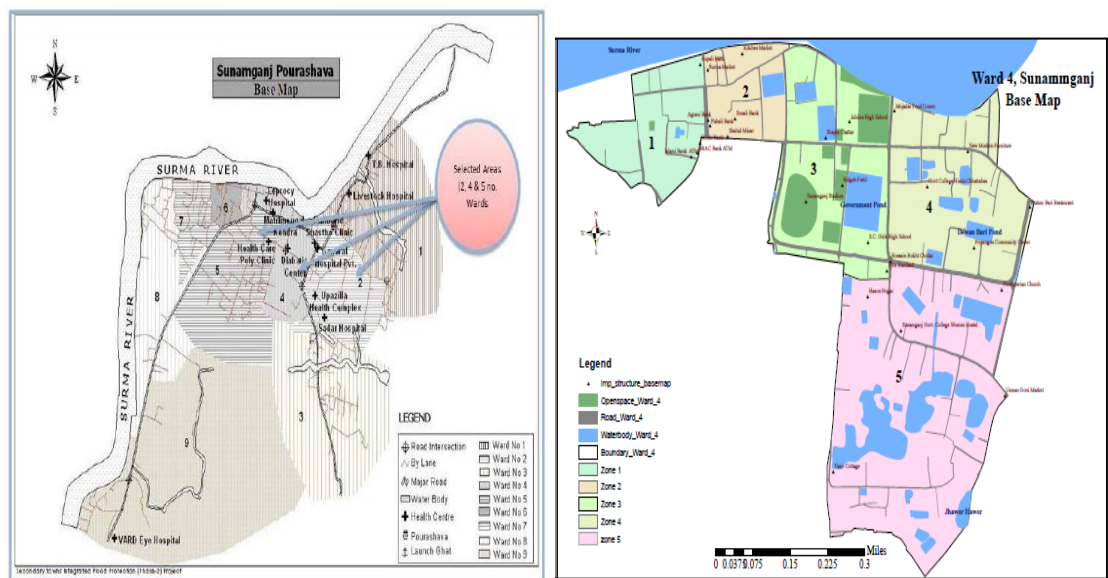

Figure 2.1: Location Map of the study area

2.2 Existing Land Use of the Study Area

In the present study, data reveals that the major land use of Ward no 4 is residential and commercial (87.7%). Rest of the structures are used for public purposes like mosque, library and administrative activity. The road network covers a major portion of land. A significant number of water bodies and open space is found in this Ward. There is also space for socio-cultural use in Ward 4.

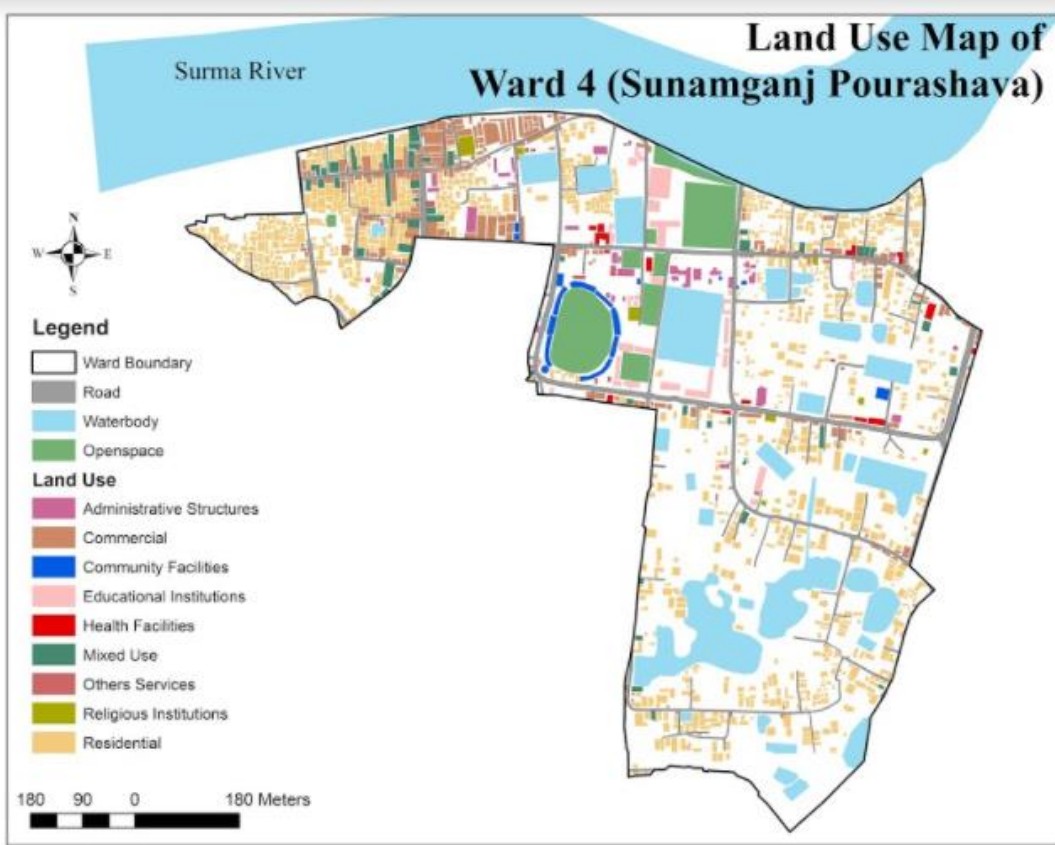

Figure 2.2: Map showing land use of the study area
(Source: Field Survey, 2020)

2.3 Profile of Built Structures in the Study Area

If the structures are described according to their types it was found from a survey of the present study that 39% of the structures of Ward No. 4 of Sunamganj Pourashava are pucca, 49% are semi pucca and the rest are katcha. Distribution of pucca buildings according to their stories is shown in Table 2.1.

Table 2.1: Distribution of pucca structures according to number of storey

Number of Story	Number of structures
Number of 1 to 3 storied building	557
Number of 4 to 6 storied building	37
Number of 7 or higher storied building	1
Total	595

(Source: Field Survey, 2020)

Among the surveyed buildings, 70.1% are of residential use, followed by commercial uses (17.5%). Apart from these uses, some buildings are used for urban services and socio-cultural purposes. Figure 2.3 shows frequency distribution of different building uses in Ward 4 of Sunamganj Pourashava.

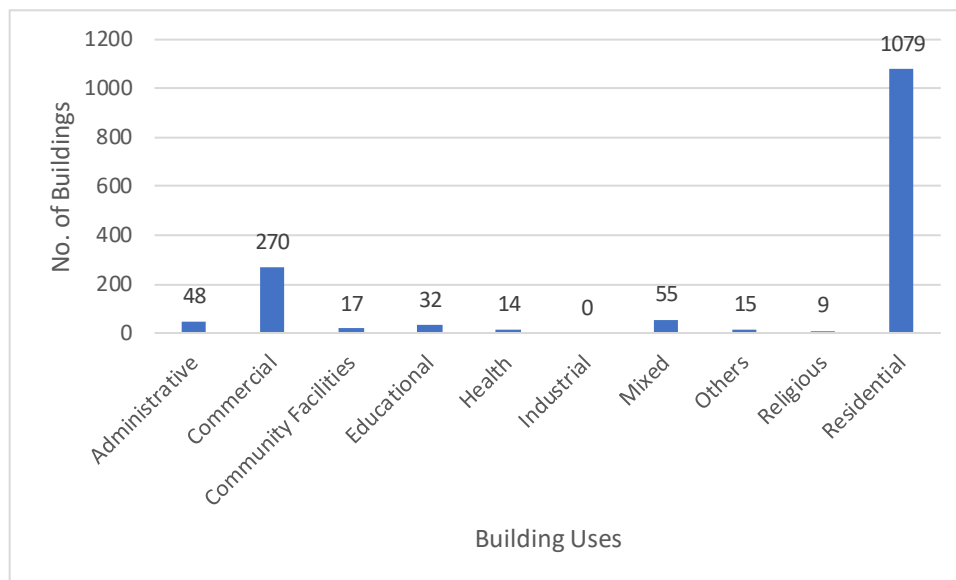

Figure 2.3: Distribution of structures according to building use
(Source: Field Survey, 2020)

There are a total 120 institutional buildings in Ward 4 having both public and private ownership. Buildings for administrative purposes, educational and religious use, health facilities and community facilities have been considered as institutional buildings in this project. Among them, seventeen buildings provide community facilities, forty-eight buildings are used as administrative offices, thirty-two buildings are educational institutes, nine buildings are used for religious purposes and fourteen buildings provide health facilities.

CHAPTER 3 : SITE SPECIFIC SEISMIC HAZARD ASSESSMENT

3.1 Introduction

This chapter deals with the borehole location and soil profile for Ward no. 4 of Sunamganj Pourashava. It also presents information regarding the microtremor test for determination of natural frequency. It will help to know the local soil condition and local seismic effect.

3.2 Borehole Data (SPT value and Description of Soil)

Figure 3.1 and Figure 3.2 represent the bore logs of the two boreholes of Ward 4 of Sunamganj Pourashava. One boring (Bore Hole 1) was done near Ukil Para and another boring (Bore Hole 2) was done near Shantibag Jame Masjid. Bore hole diameter used in these tests was 100 mm. Both disturbed and undisturbed samples were collected from the borings. 20 readings of SPT-N value at 1.5m intervals up to 30 m were taken.

The soil profile of bore hole 1 in Figure 3.1 shows five different layers of soil. The N value up to 10.5m is less than 5. Thus, the top 10.5m have poor strength characteristics as both cohesion and angle of internal friction are positively correlated to SPT-N value (Kumar et al., 2016). Moreover, a layer of organic clay with peat was located from 7.5m to 9m. The SPT-N value increases beyond 10.5 and reaches a maximum of 28 at 16.5m. As the depth increases further, the N value remains within 20 to 24, with an exception at 24m where the value becomes 27. The detailed description of the soil types is shown in Figure 3.1.

The soil profile of bore hole 2 in Figure 3.2 also shows five different layers of soil. However, no organic soil was detected in this borehole. Up to 7.5m, the SPT-N value remains below 5 resulting in low soil strength. The SPT-N value increases beyond this depth with occasional fluctuation and reaches at a value higher than 20 (N=24) at 18m. At the last layer of medium dense sandy silt, the N values stay mostly steady among 18-24. However, the maximum value of 26 is obtained at 27 m. Though from the comparison of both the boreholes it can be observed that their strength characteristics

are quite similar, the presence of organic soil in borehole 1 shall be carefully considered during construction.

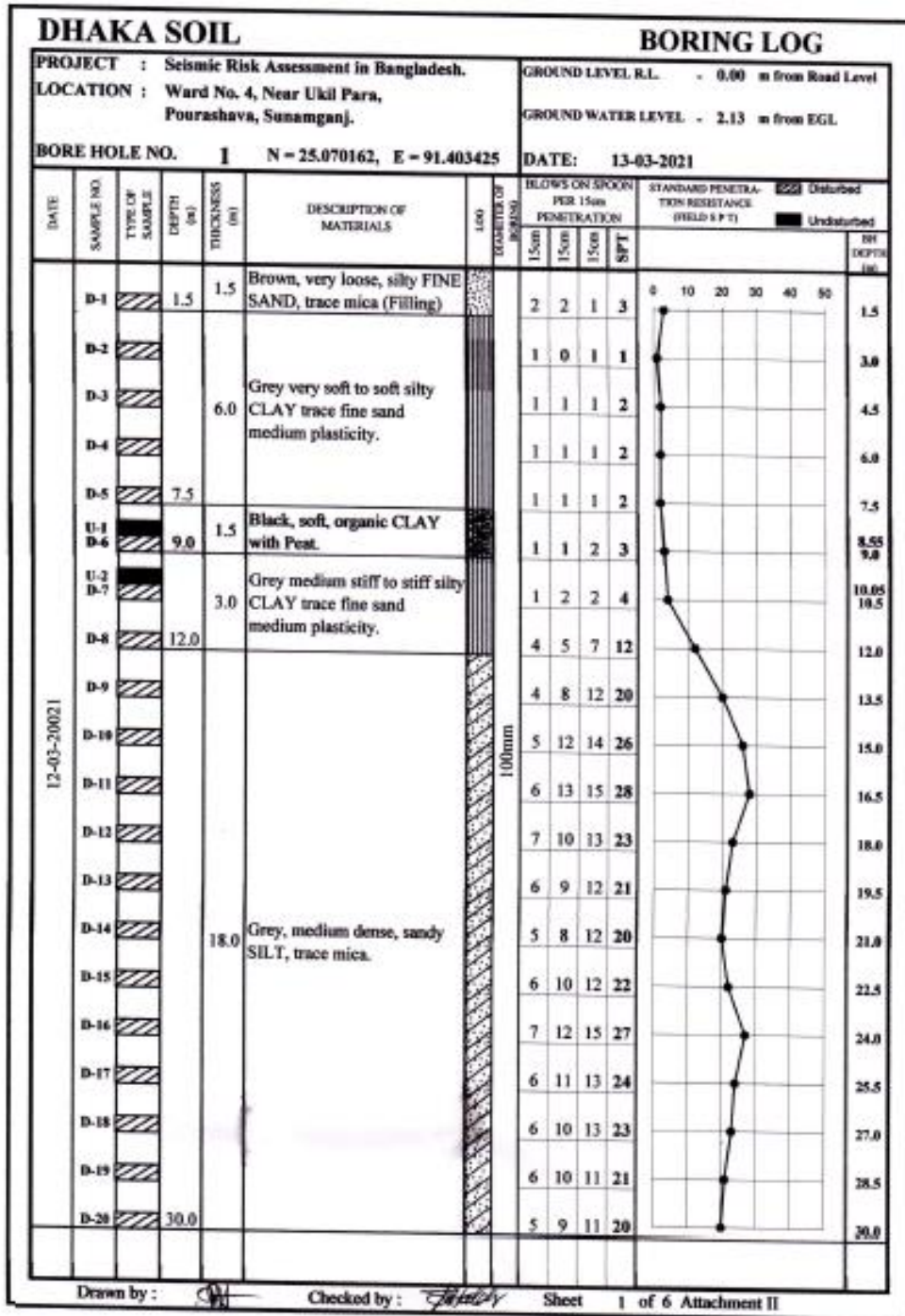

Figure 3.1: SPT data of Bore Hole 1 of Ward 4

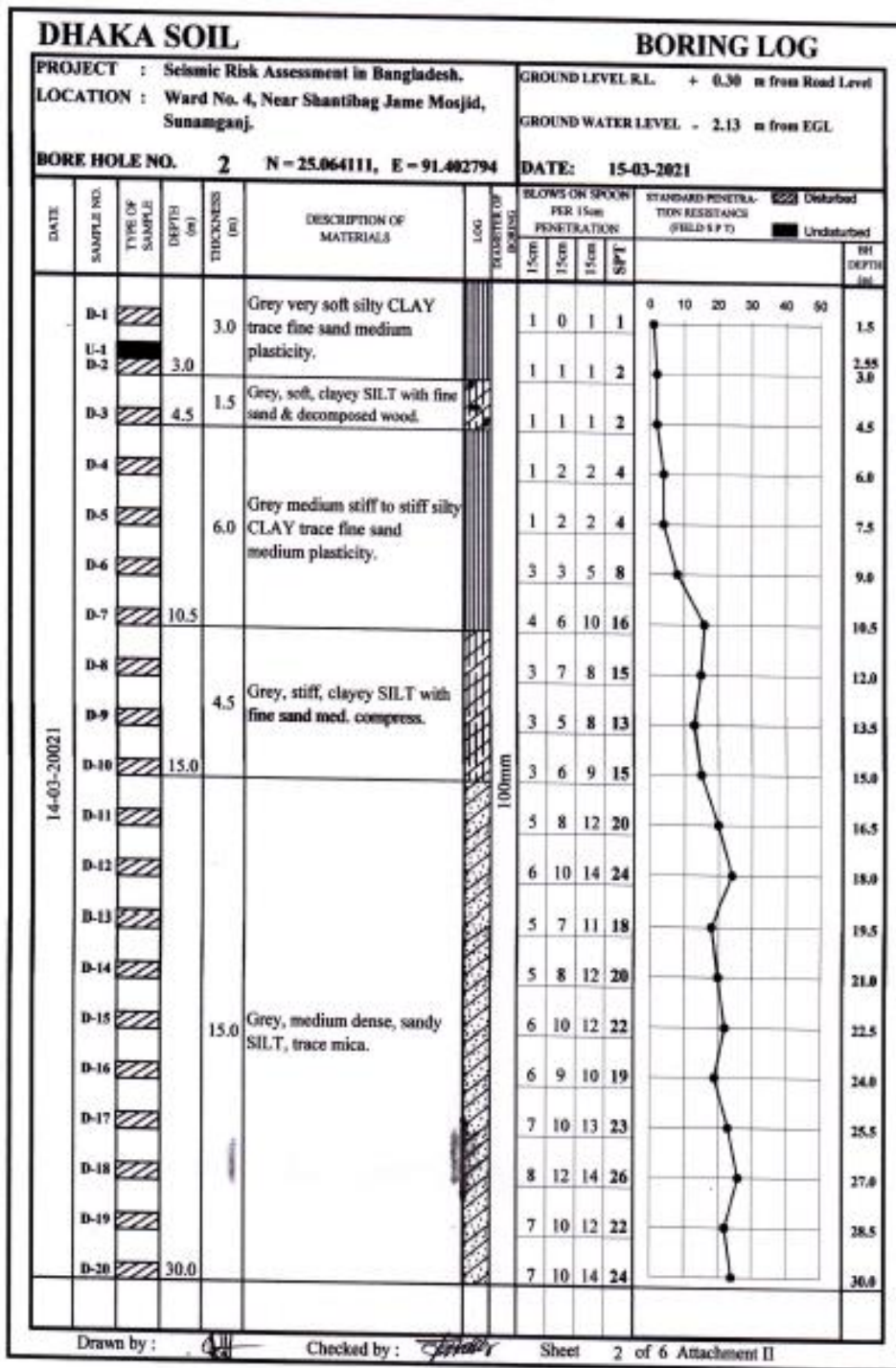

Figure 3.2: SPT data of Bore Hole 2 of Ward 4

3.3 Microtremor Test

Microtremor test was conducted at one location of ward no. 4 of Sunamganj Pourashava. The methodology has been stated in Chapter 2 of Volume 1.

3.3.1 Result of Microtremor Analysis

For the microtremor test, data was recorded for one hour at a sampling frequency of 100 Hz. For each sensor the data set has been divided into 25 segments each containing 8192 data points. After segmenting the data set the data was filtered through a band pass filter to eliminate very high and very low frequencies. Fast Fourier Transformation (FFT) has been used to transfer time domain data of each window to frequency domain data.

By dividing the horizontal component (vibrations recorded in N-S and E-W directions) by the vertical component (vibrations recorded in Up-Down direction) we obtained the amplitude. All the graphs have been smoothed by averaging 20 data points and considering it as a single point in the graph. This was repeated for 25 sections and the geometric average of the amplitude ratios was taken to finally plot the Amplitude ratio vs Frequency (Hz) graph.

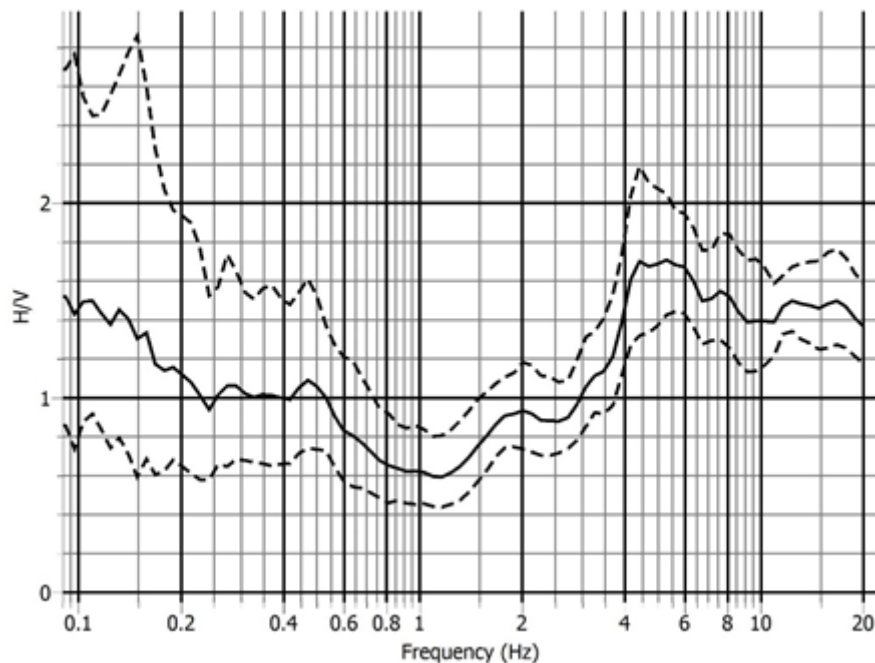

Figure 3.3: Amplitude Ratio vs Frequency graph of Ward no. 4 of Sunamganj Pourashava

Figure 3.3 shows the Amplitude ratio vs Frequency graph for Ward 4 of Sunamganj Pourashava. From the graph we can observe that the amplitude ratio is maximum at around 4.5 Hz. The frequency at which the amplitude ratio shows a prominent peak is considered to be the predominant/natural frequency of the soil at that location. So, the predominant frequency is around 4.5 Hz. The predominant period is 0.22s. Using empirical equations along with the soil profile obtained from the bore holes, the shear wave velocity of the 30 meter 1-D soil column was found to be around 129.05 m/s (Bore hole-1) and 130.78 m/s (Bore hole-2).

CHAPTER 4 : BUILDING VULNERABILITY ASSESSMENT

4.1 Introduction

In this chapter, the seismic vulnerability of the buildings of Ward no. 4 of Sunamganj Pourashava has been discussed based on Rapid Visual Screening of 108 buildings.

4.2 Preliminary Assessment using Rapid Visual Screening

The seismic vulnerability assessment of structures in the selected area has been done by RVS (Rapid Visual Screening) method formulated in FEMA P-154. In this method, the main focus was on issues which may cause damage during earthquakes such as identifying building type, plot size and shape, clear distances from surrounding structures, road width and basic information of the building: year of construction, number of storey, overhang, vertical irregularity, plan irregularity etc. Digital photographs of each building from at least two directions were taken.

4.3 Results and Discussion of Preliminary Vulnerability

Assessment

In this section, results of the analysis are presented focusing on the main concerning point of the structure which may turn out to be vulnerable during earthquakes.

Ward no. 4 of Sunamganj Pourashava has been divided into 6 clusters. This ward falls within a moderately high seismicity zone according to FEMA and preliminary analysis has been done considering an earthquake magnitude of $7 \leq M_w < 8$. Later a worse case scenario was considered for an earthquake magnitude greater than 8.0. Six different types of buildings were obtained during the rapid visual screening of the selected buildings in Sunamganj Pourashava. These, according to classification of FEMA are Wood Light Frame (W1), Light Metal Building (S3), Steel Frame Building with Unreinforced Masonry Infill Walls (S5), Concrete Shear Wall Building (C2), Concrete Frame with Masonry Infill Walls (C3) and Unreinforced Masonry building (URM). The maximum achievable score for these six types of buildings are 4.1, 2.5, 2.1, 2, 1.4 and 1.2 respectively (as per FEMA requirements). However, as we consider the irregularities and soil class (D) the scores decline. So, an URM type building cannot

receive a score greater than 1.2 in any circumstances. If a cut off score greater than 1.2 is set, it will not represent the true state of vulnerable buildings. Thus, a cutoff score of 1.2 has been selected. It has been observed that for the general case, the final score of 21% of the total surveyed buildings in ward 4 were below cutoff (1.2) and thus these are vulnerable. Table 4.1 presents the percentage of vulnerable buildings in each cluster.

Table 4.1: Percentage of vulnerable buildings in different clusters

Cluster	Number of Building Surveyed	Number of Vulnerable Buildings	Percentage of Vulnerable Buildings
1	25	2	8%
2	4	1	25%
3	39	5	13%
4	24	3	13%
5	15	9	60%
6	1	1	100%

Figure 4.1 (a and b) represent relations between percentage of buildings and RVS score of Ward 4 for the general case ($7 \leq M_w < 8$) and worse case scenario ($8 \leq M_w$).

Figure 4.1 (a) indicates that 5% of the buildings has a score less than or equal 0.3, 3% of the buildings has a score in between 0.4 to 0.6, 10% of the buildings score in between 0.7 to 0.9, 3% of the building has score in between 1-1.2, 76% of the building score in between 1.3-1.5 and finally 3% building has a score greater than 1.5. Thus, 79% of buildings can be marked as safe during an earthquake of lower magnitude.

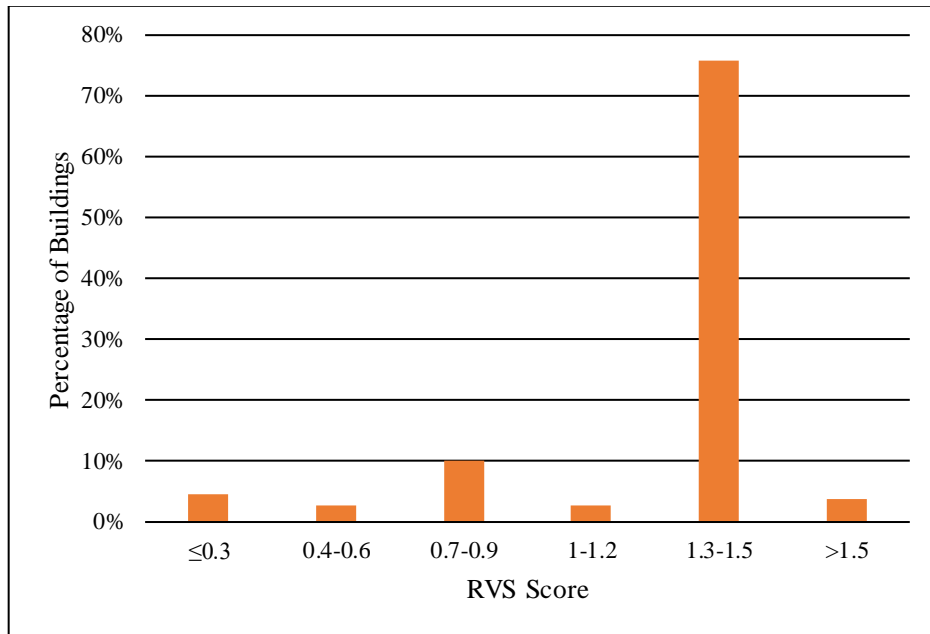

Figure 4.1 (a): Relations between percentage of buildings and RVS score of Ward 4 for moderately high seismicity

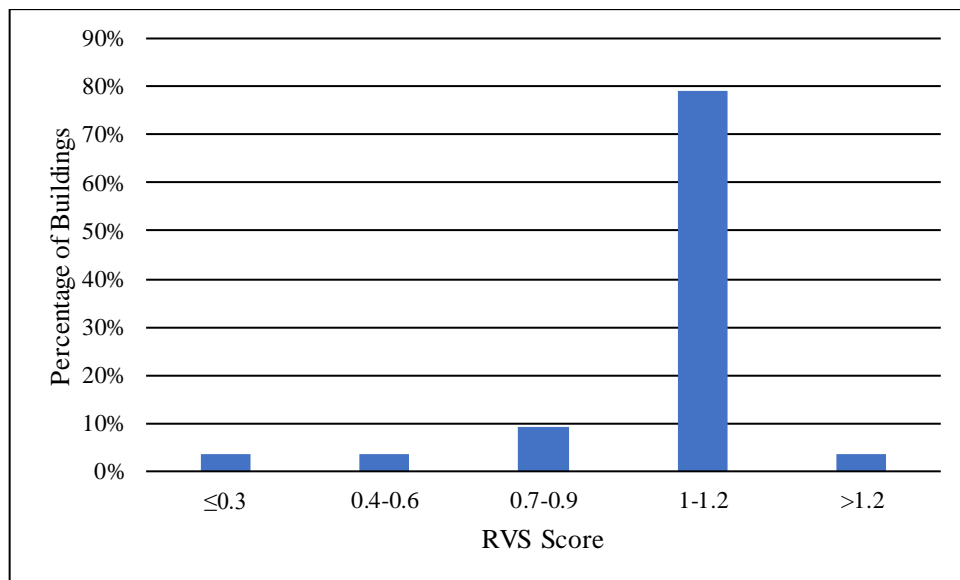

Figure 4.1 (b): Relations between percentage of buildings and RVS score of ward no 4 for high seismicity

Figure 4.1 (b) shows that 4% buildings score less than or equal 0.3. 4% score in between 0.4-0.6. 9% buildings were within the range of 0.7-0.9, 79% scored between 1.0-1.2 and finally 4% of the buildings scored higher than 1.2. Thus considering a cutoff of 1.2 for higher seismicity, 4% buildings will be marked as safe during earthquakes of higher magnitude.

Figure 4.2 shows the percentage of buildings against the total number of stories. It was observed that 3 story buildings are dominating in this ward and it is 30% of the total sample size. Then 2 story buildings comprised 23%, followed by 1 story building which is 21% of the sample size. 4 story and 5 story buildings comprise 11% and 10% of the total surveyed buildings, respectively. 4% of the buildings are 6 stories. Only 1% of the building is above 6 stories.

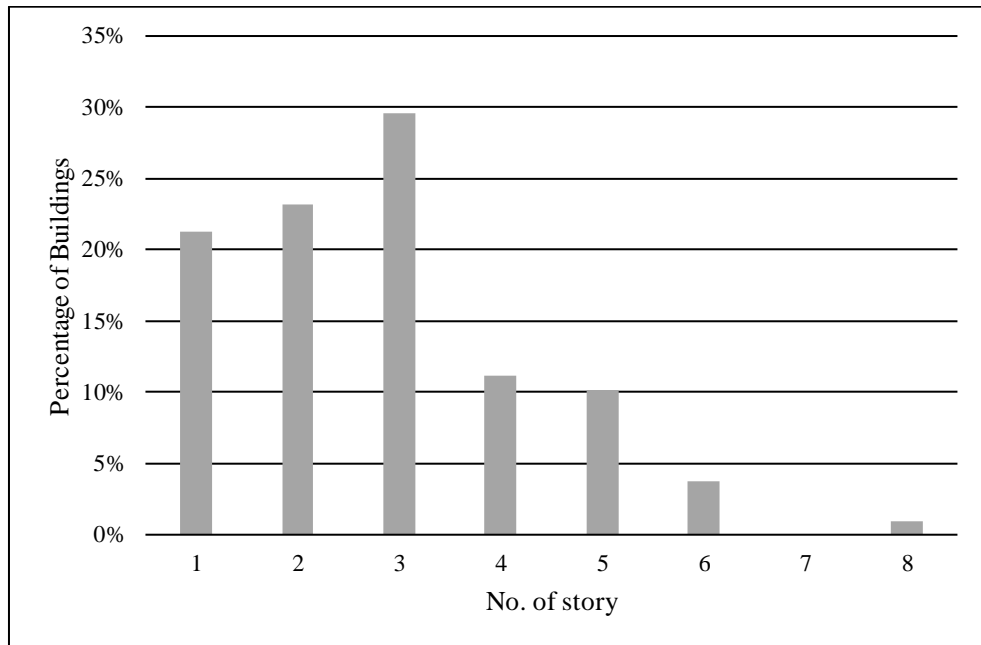

Figure 4.2: Relations between the percentage of buildings and no. of story of Ward 4

It was found that among the 108 surveyed buildings, 101 buildings are Concrete Frame with Unreinforced Masonry Infill Walls (C3 as per FEMA classification), 5 buildings are Concrete Shear Wall Building (C2 as per FEMA classification), 1 building is Unreinforced Masonry building (URM as per FEMA classification), and 1 building is Steel Frame Building with Unreinforced Masonry Infill Walls (S5 as per FEMA classification). Figure 4.3 represents different percentages of buildings found in ward 4. Hence, the C3 type building dominates in the study area.

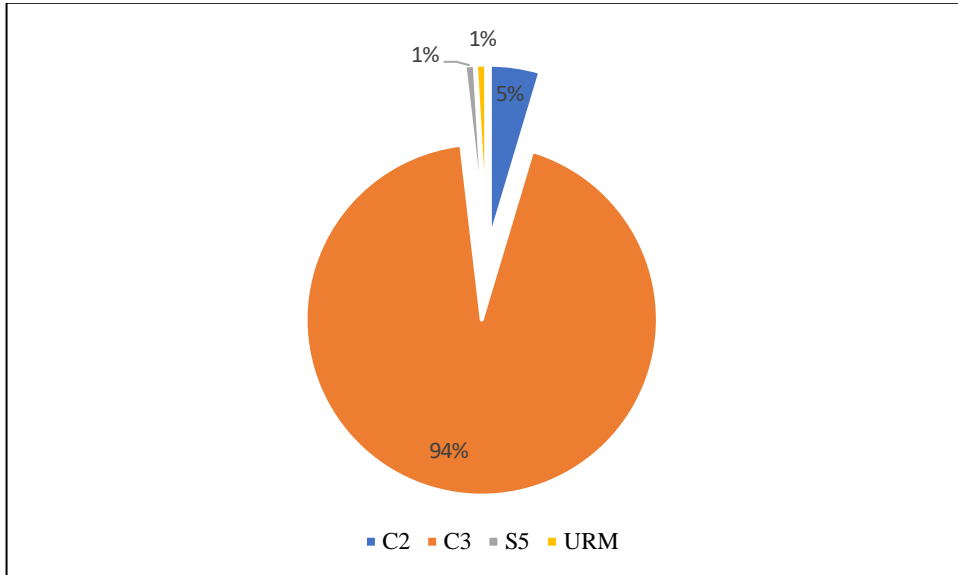

Figure 4.3: Percentage of Different Building Types

Figure 4.4 represents relation between percentage of buildings and severe vertical irregularity which include any or a combination of the following: short column, soft story/weak story and out of plane setback. It has been observed that 8% of the buildings that were surveyed have severe vertical irregularity.

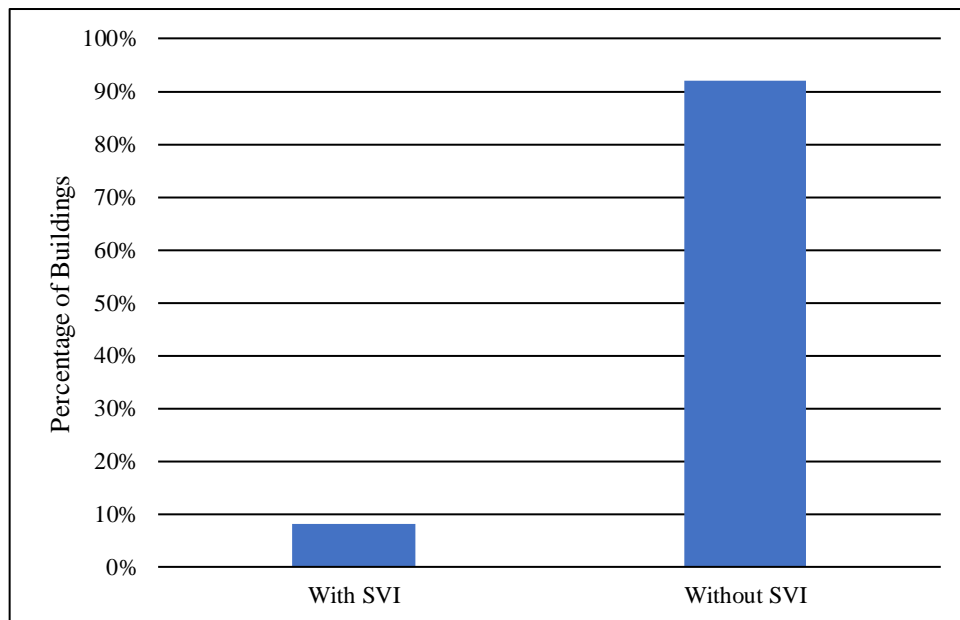

Figure 4.4: Relations between percentage of buildings and severe vertical irregularity

Figure 4.5 represents relation between percentage of buildings and moderate vertical irregularity (e.g. in plane setback, sloping site, split level). It is found that 8% of the buildings have moderate vertical irregularity.

Figure 4.6 represents relation between percentage of buildings and plan irregularity (e.g. torsional irregularity, non-parallel system, reentrant corner, diaphragm opening, out of plane offset). 8% of the buildings have one or more forms of plan irregularity.

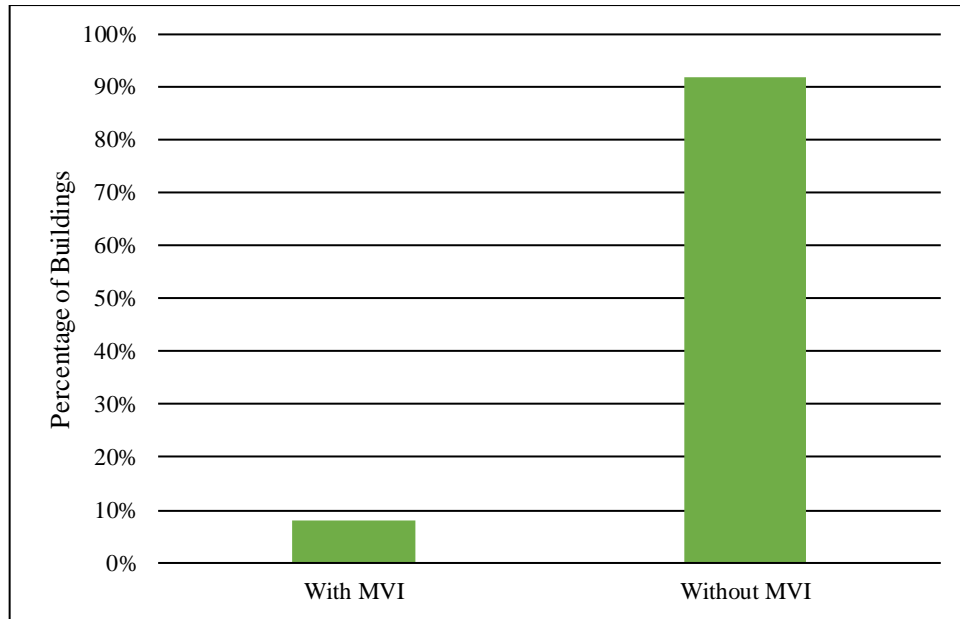

Figure 4.5: Relations between percentage of buildings and moderate vertical irregularity

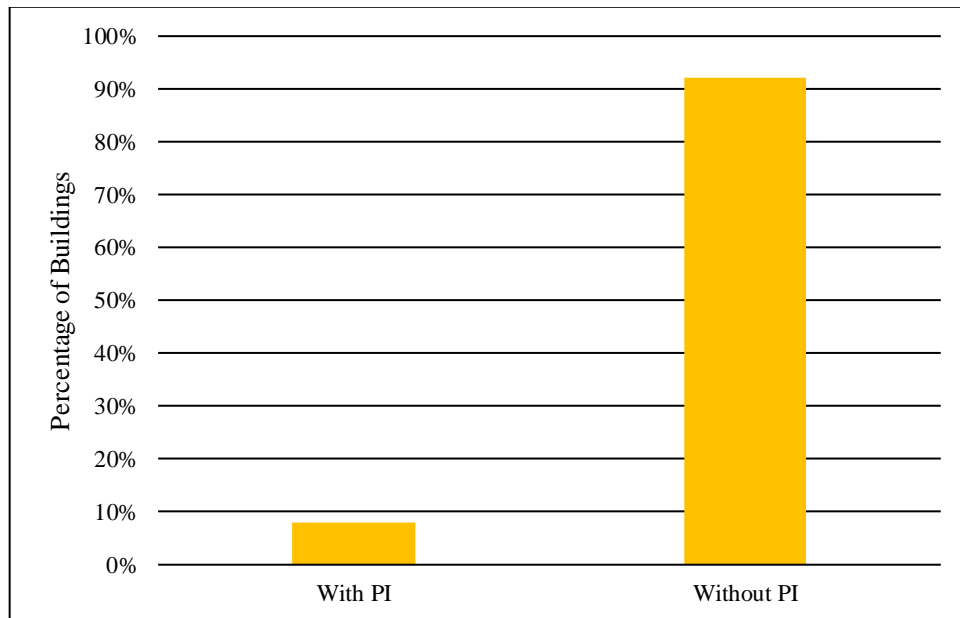

Figure 4.6: Relations between percentage of buildings and plan irregularity

CHAPTER 5 : DETAILED ENGINEERING ASSESSMENT

5.1 Introduction

Rapid Visual Screening (RVS) provides a preliminary idea regarding the condition of the structures. To get a detailed picture of the condition of the structural members further investigations are necessary. With this view, a detailed engineering assessment of one building was conducted in ward no. 4 of Sunamganj Pourashava.

The initial approach for selecting a building considered two criteria: it needed to be a public building and needed to be accessible during the time of an earthquake. Also, it was discussed with the respected councilor of the ward and local representatives whether this building can be used as the ward coordination center (WCC) during earthquakes. Based on the mentioned criteria Govt. S C Girls High School was selected for detailed engineering assessment (DEA).

A technical team from BUET-JIDPUS visited the building in September 2021 to visually assess the structural condition of the building. They performed some tests to evaluate the existing condition of the building. Core samples were collected to get an idea about the strength of the concrete. Moreover, foundation locations were excavated to make a spot examination of the foundation depth and foundation dimensions. Finally, a detailed analysis was done for checking the structural design adequacy of the building. This report provides a summary of the methodology, loading conditions, material properties, and parameters used in the analysis of the structure. The report concludes with comments on the structural adequacy of the building.

5.2 Salient Features and Drawing of the Building

No previous drawing of the building was available and thus the following drawings were prepared as a part of the detailed engineering assessment.

- Architectural Floor Plan
- Structural Drawings

The drawings have been attached in Appendix C.

Based on visual observations and drawings the following features were noted for the building.

- (i) Building Usage Type : School Building
- (ii) Structural System : Reinforced Concrete Moment Resisting Frame
- (iii) Floor System : Beam supported RC slab
- (iv) Floor Area : The building plan dimension is 136 ft × 33 ft. Approximately floor area is 4488 sft per floor.
- (v) No. of Stories : 2
- (vi) Foundation Type : Reinforced Concrete Foundation (Shallow)
- (ix) Construction Materials : Reinforced concrete
No test report of construction materials is available.

5.3 Assessment of As-Built Condition

5.3.1 Assessment of Concrete Strength

Strength of the concrete in the existing beams, columns and slabs has been assessed by extracting concrete core samples. Figure 5.1 shows the extraction of core from a column. Location of core cutting and their respective strength has been provided in Appendix C. Variations have been observed in the concrete strength derived from tests of the core samples. This may have resulted due to the quality control issue and other uncertainties associated with the core collection and testing (Ahsan et al., 2018). Hence, by applying judgment, concrete strength has judiciously been considered between the lowest and mean value. From these results, concrete compressive strength of 1.8 ksi for slab, column and beam of the building has been used for the structural analysis on finite element software.



Figure 5.1: Core extraction from a column

5.3.2 Ferro-Scan Test for Reinforcement Identification

Ferro-scan tests of the building have been done to know the number and size of reinforcement in column, slab and beam. All scanned images of the Ferro-scan results are attached in Appendix C.

5.3.3 Checking the Foundation

Foundations of the building were checked by excavating the soil. The size, thickness and depth were measured. Figure 5.2 shows the excavation of footing. Footing details have been attached in Appendix C.



Figure 5.2: Footing excavation

5.4 Finite Element Modeling

The following building is analyzed in ETABS 16.0 considering floor finish 25psf, partition wall load 45psf, live load 100 psf for school building and 100 psf for stair and lobbies. Required values for analysis have been taken from BNBC 2020. Zone coefficient $Z = 0.36$ for Sunamganj Pourashava according to table 6.2.15 is used. Site coefficient is taken 1.35 according to table 6.2.16 considering soil type SD (as N value within 20m is $15 < N < 50$) for Sunamganj Pourashava. The SPT value for soil is shown in Chapter 4 using soil test results. As all the buildings are school buildings (Occupancy Category III, according to table 6.1.1), the importance factor is taken 1.25; according to table 6.2.17. Response modification factor is taken $R = 8.0$ according to

table 6.2.19. for Special Reinforced Concrete Moment Frame system for Seismic Design Category D according to table 6.2.18. Wind speed (61.1 m/s) is taken according to table 6.2.8. Material properties are taken from the core test result shown in Appendix C. Used load combination according to section 2.7.3.1 are shown below where D=Dead Load, L= Live Load, E= Earthquake Load, W= Wind Load:

1. $1.4 D$
2. $1.2 D+1.6 L$
3. $1.2 D+ L$
4. $1.2 D+1.6 W+ L$
5. $1.2 D+ E+ L$
6. $0.9 D+1.6 W$
7. $0.9 D+ E$

5.5 Results

It is a two-storied school building. As-built drawings of this building are shown in Appendix C. Figure 5.3 depicts the 3-D view of the finite element model. Figure 5.4 shows the 3-D view of the structure after analysis with the required amount of reinforcement. The red marked columns indicate that they are overstressed and failed due to the applied loading condition. Similarly, the red marked beams indicate that the beams failed in flexure. But for this particular analysis, no red marked beam was identified (see figure 5.4); hence the beams of this building did not fail in flexure due to considered loading conditions.

Figure 5.5 identifies the overstressed columns (shown in “Red”) along Frame 2-ABCDEFGHIJKLMN and 3-ABCDEFGHIJKLMN in elevation view. Hence to use the structure in the future as a ward coordination center, necessary retrofitting of the inadequate columns need to be done.

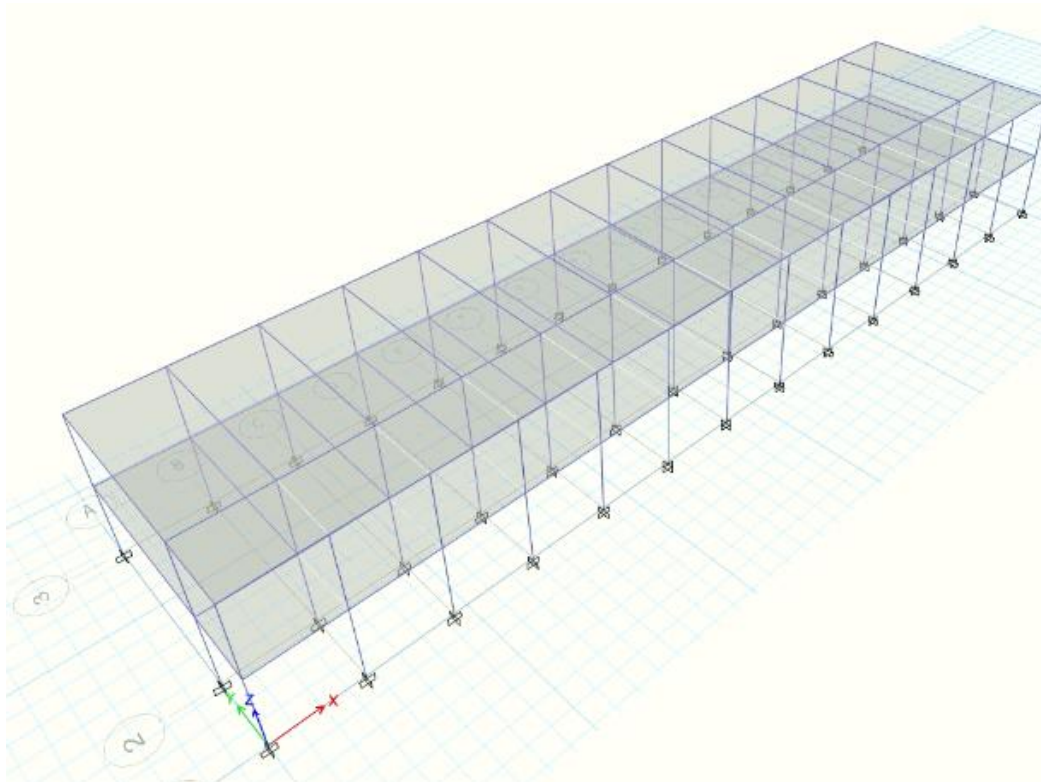

Figure 5.3: 3-D view of the finite element model before analysis

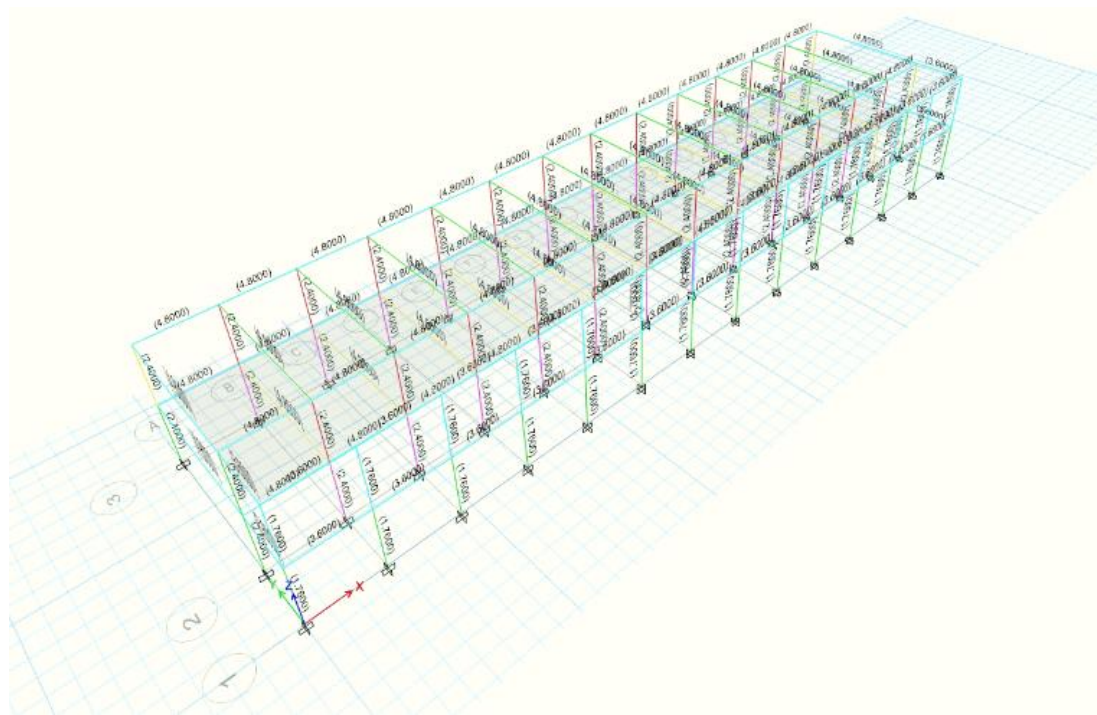
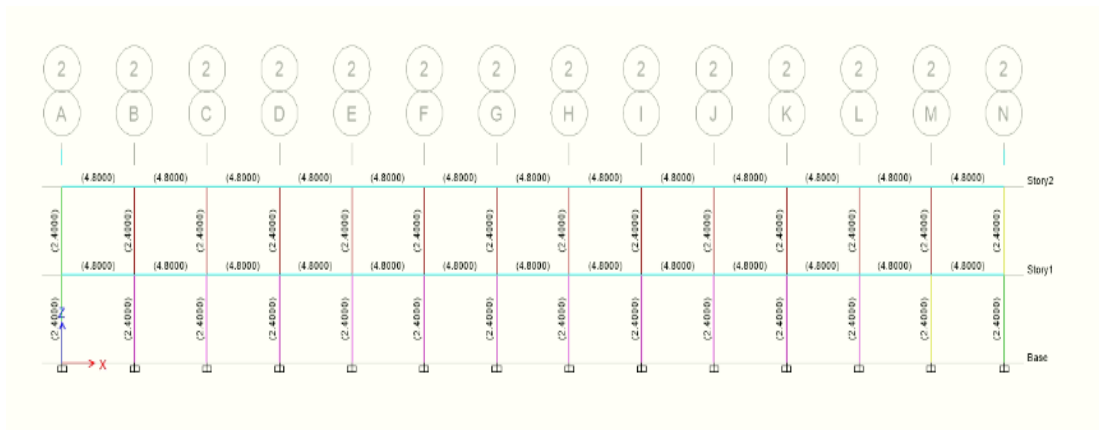
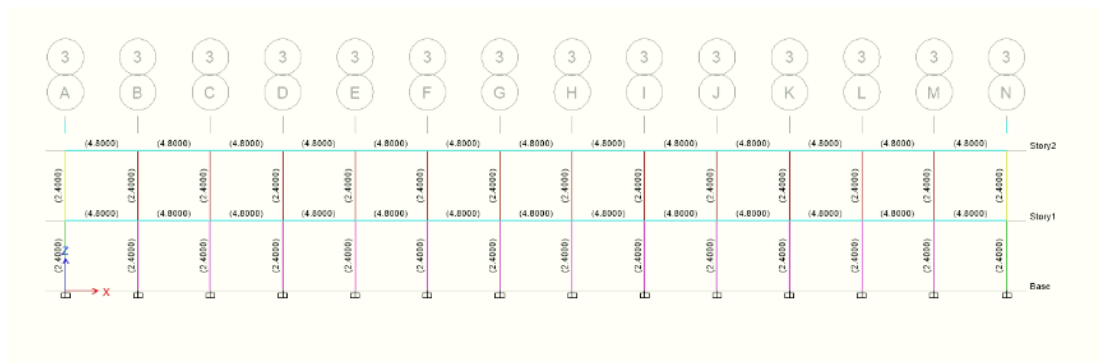

Figure 5.4: 3-D view of the building in FEM after analysis with reinforcement details



(a)



(b)

Figure 5.5: Elevation view to identify overstressed columns along (a) 2-ABCDEF... (b) 4-ABCDEF... frames

CHAPTER 6 : SOCIO-ECONOMIC VULNERABILITY ASSESSMENT

6.1 Introduction

Socio-economic vulnerability of a community is defined as the condition of a community which has unequal participation in decision making process, weak or no community organizations; discriminative economic standard, social norms and values, political accountability, variation of income and production etc. (Mnestudies.com, 2018). Socio-economic vulnerability examines social and economic factors and how the combination of both social context and economic condition influence an area of interest or study (Brouwer, 2018). A devastating earthquake does not only kill people, damage or destroy buildings and infrastructures, but also cause damage and destruction of centers of economic, cultural and social activities. By causing massive destruction to individual buildings, critical facilities, or economic and cultural centers, earthquake disturbs or destroys the existing inter-relationship and interaction between or among the different groups and activities of a society or a nation (ADPC, n.d.). Socio-economic vulnerability is highest among the poorest people in developing countries because of lack of information and resources. Within this group, children, women and the elderly are considered to be the most vulnerable. To reduce such vulnerability, it is necessary to identify the knowledge and understanding of the local residents (Mnestudies.com, 2018). This chapter focuses on the analysis of socio-economic vulnerability of Ward No. 04 of Sunamganj Pourashava. The socio-economic issues considered here include general profile of the respondents and their family members (age, sex, educational qualification, occupation, house ownership, earthquake training, data of physically challenged people etc.), perception regarding earthquake risk, perception about earthquake preparedness and their eagerness to get involve with these types of volunteering works etc. The analysis has been done on the basis of household questionnaire survey of 66 households which includes total 309 members.

6.2 General Socio-economic profile of surveyed population

To understand the socio-economic profile of the study area, gender and age composition, occupation, education level and physical disability status of total 309

members of 66 households were analyzed. Additionally, monthly household incomes, buildings ownership, duration of stay in the area of 66 households were also analyzed.

6.2.1 Gender and age composition

Data of 309 individuals of 66 surveyed households who live in Ward 04 of Sunamganj Pourashava were collected for the study through the method described in Chapter Three. It has been observed that distribution of male and female is very close and almost equal (Male 48.2% and Female 51.8%). So, there is no scope to exclude any gender group rather, special needs and requirements of both groups must be incorporated in different disaster management activities so that they can respond in the case of any disaster.

Table 6.1 shows the distribution of the members from surveyed households of Ward 04 according to their age group. For the convenience of analysis, the members of the surveyed households have been divided into five age groups, i.e. children (<10years), young (11-20 years), young adults (21-30 years), middle aged (31-60 years), and elderly (>60 years). From table 6.1, it is visible that, highest percentages (55%) of the inhabitants of the surveyed households belong to age group 21-60. It is also necessary to note that a significant share of the members are children (12%) and elderly people (11%), who will require assistance after an earthquake.

Table 6.1: Distribution of respondents according to their age group

Age Group	Number of residents	Percentage
Less than 10 years	38	12%
11 to 20 years	68	22%
21 to 30 years	62	20%
31 to 60 years	106	35%
More than 60 years	35	11%
Total	309	100%

(Source: Field Survey, 2021)

6.2.2 Occupation

Figure 5.1 shows the distribution of 309 members of the surveyed household according to their occupation. From the figure 6.1, it is visible that almost one third of the inhabitants (36%) of the surveyed households are student and 26% members from surveyed households are housewives. So there is a wide scope to engage these students in disaster management activities through awareness building and proper training.

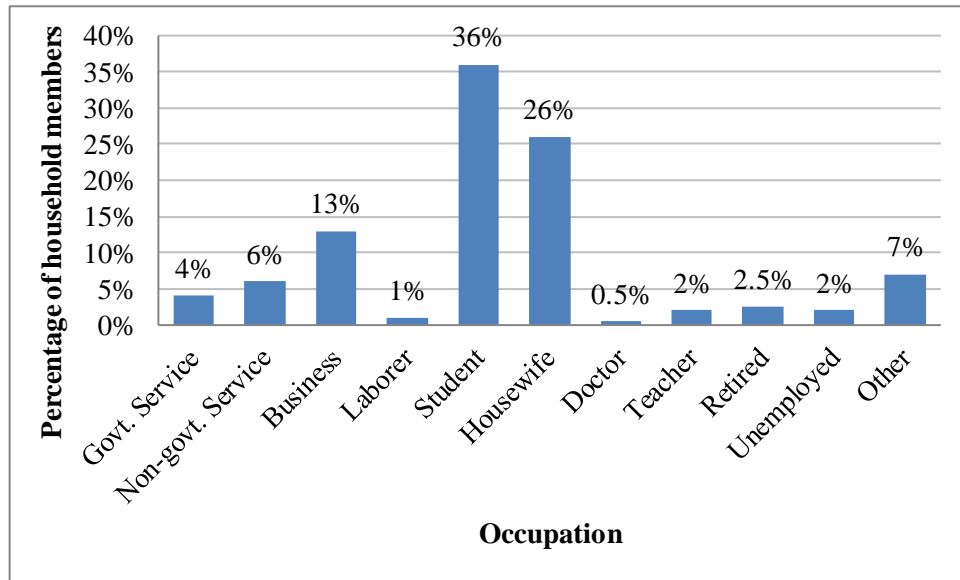

Figure 6.1: Distribution of household members according to their occupation

(Source: Field Survey, 2021)

6.2.3 Educational qualification

Figure 6.2 shows the distribution of educational qualification of 309 members of 66 households of the ward. The highest percentage of the members of the surveyed households has educational qualification up to secondary level (34%) followed by primary level (19%) and graduate level (16%). Only 9% of the inhabitants from the surveyed households are illiterate where the national illiteracy rate in Bangladesh is almost 30% (BBS, 2019).

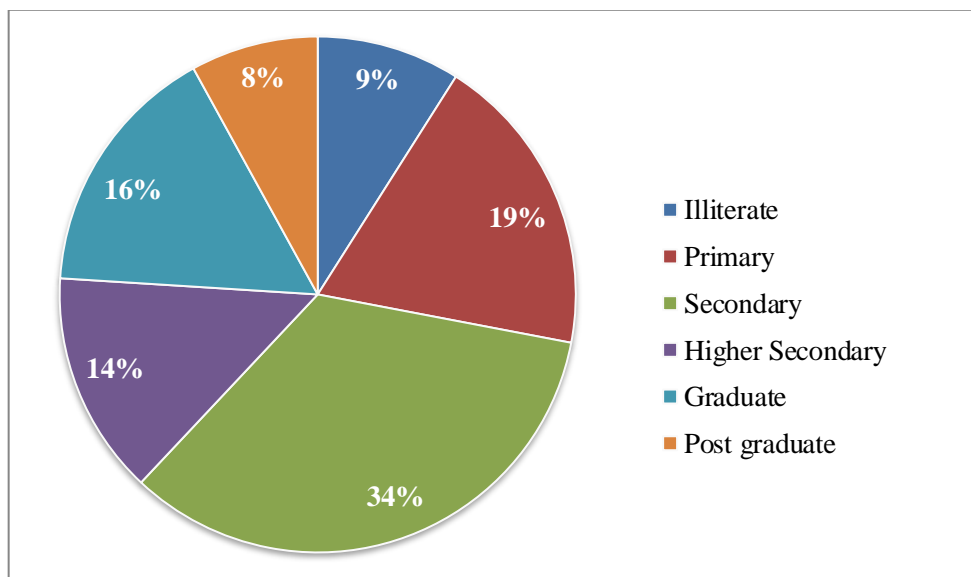

Figure 6.2: Distribution of household members according to educational qualification
(Source: Field Survey, 2021)

6.2.4 Physically/mentally challenged population

Physically/ mentally challenged people would need assistance after an earthquake. So, it is important to consider them to ensure proper earthquake response. However, it has been found from the survey that no members from the surveyed households are physically or mentally disabled.

6.2.5 Monthly household income

Monthly income of majority portion of the surveyed households (66 households) is less than 40,000 BDT (Figure 6.3). 32% households have monthly income of less than 20,000 BDT. More than 50,000 BDT per month is earned by 9% of the surveyed households.

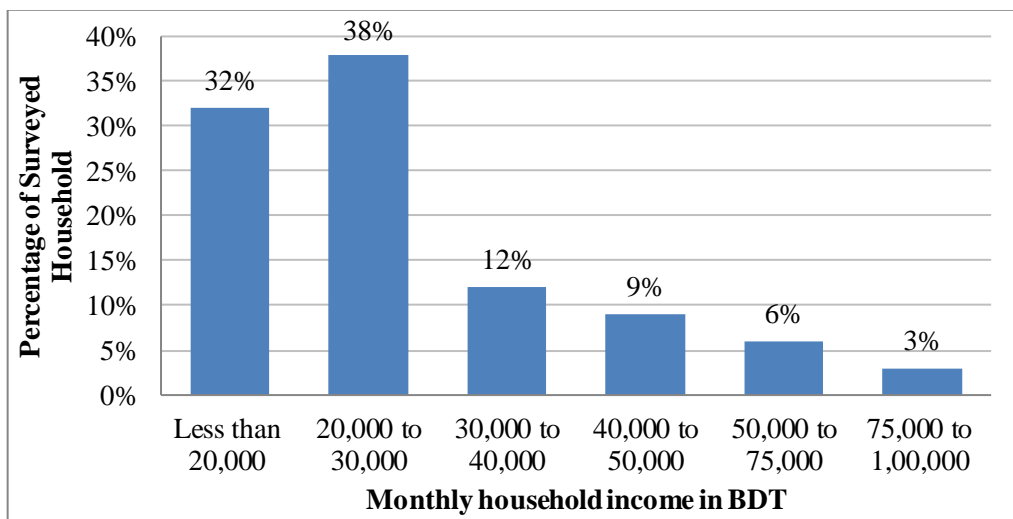

Figure 6.3: Distribution of monthly household income of the surveyed household
(Source: Field Survey, 2021)

6.2.6 Building ownership

Figure 6.4 indicates that the buildings in which the surveyed households reside are mostly under private ownership (92% personal ownership and 2% joint ownership). Only 6% of the buildings were found to be under government ownership.

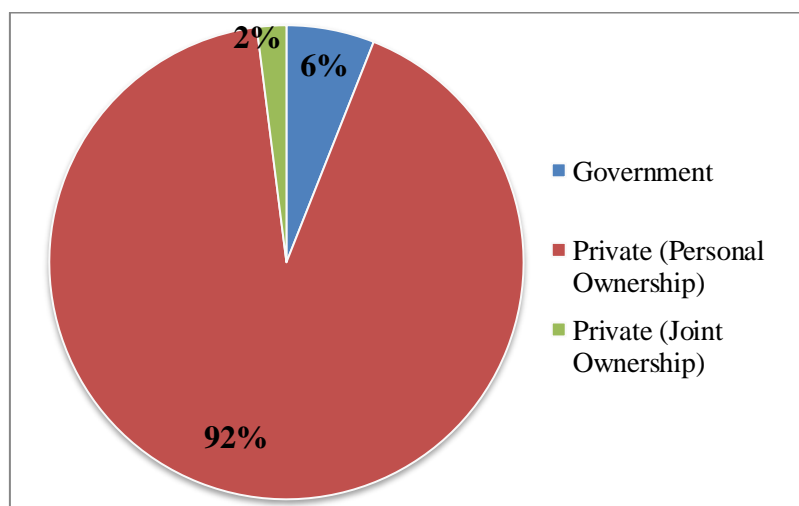

Figure 6.4: Distribution of households according to the ownership of the buildings
(Source: Field Survey, 2021)

6.2.7 Duration of stay in the area

From Figure 6.5 it is visible that, 56% of the surveyed families live in this area for more than 20 years. 20% of them have been living in this area for 11 to 20 years. From this data, it can be concluded that, as majority of the people live here for many years,

they have better knowledge about the area and the inhabitants. It is also understood that their sense of belonging to the place and the community bonding are strong.

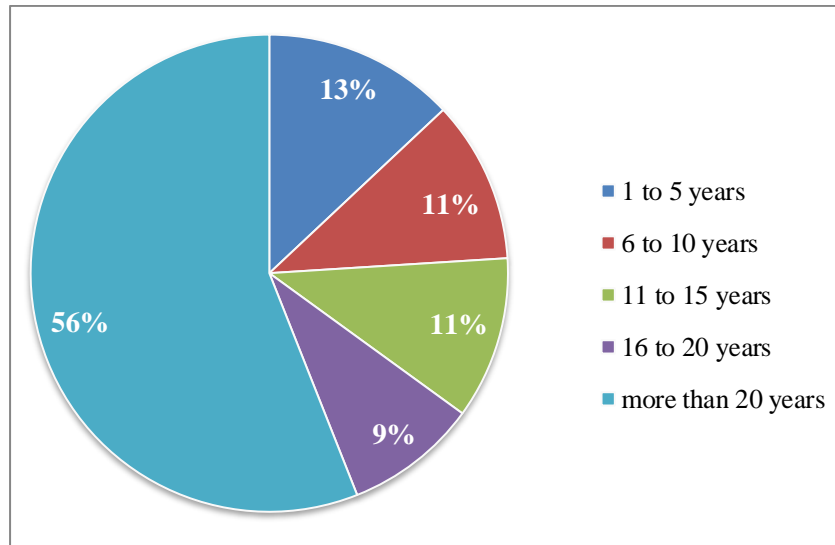

Figure 6.5: Distribution of households according to their duration of stay in the area
(Source: Field Survey, 2021)

6.3 Awareness Status and Knowledge of People about Earthquake

To understand the actual level of awareness of respondents about earthquake, their awareness status has been analyzed with respect to their social context and sources of their awareness.

6.3.1 Awareness status and overall knowledge of people

Among 66 surveyed respondents, 79% have responded that they are aware of earthquake. From Table 6.2, it is visible that, majority of the respondents who are aware of earthquake knows that, earthquake is a natural disaster that causes vibration of the physical structure. 55% of them know that earthquake can cause infrastructural damage and 44% of them know that it occurs due to the movement of earth surface plate. So, it can be concluded that majority of them have knowledge about the basic causes and impacts of earthquake.

Table 6.2: Detail knowledge of respondents about earthquake

Knowledge	Frequency	Percent
It is a natural disaster	48	92%

Occurs due to movement of surface plates on earth	23	44%
Causes vibration of the physical structures	48	92%
Can cause infrastructural damage	29	55%
Can cause life risk	11	21%
None of these	0	0%

(Source: Field Survey, 2021)

6.3.2 Source of awareness about earthquake

From Figure 6.6 it can be observed that majority of them learned about earthquake from mass media. Except these, social media is another important source. The numbers of respondents, who have learned about earthquake from earthquake drill or earthquake related programs, are comparatively lower. This represents that earthquake drill or earthquake related programs are unable to reach the majority of population in the study area.

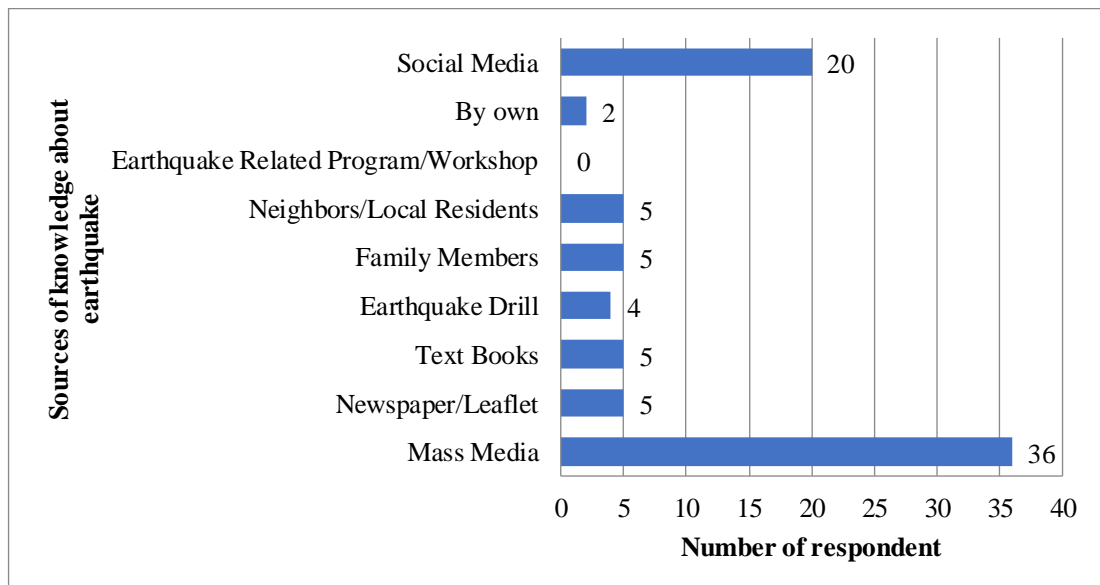

Figure 6.6: Sources of knowledge of earthquake of the respondents

(Source: Field Survey, 2021)

6.3.3 Preferable medium for raising awareness

Now it is important to know which mediums the respondents prefer the most for raising awareness about earthquake and reducing earthquake risk. From Table 6.3, it is visible that, when ranking different options, highest number of respondents (65) selects mass media (television/radio etc.) as their first preferred medium. Newspaper/leaflet is chosen as 2nd choice by maximum 60 respondents and locality based meeting/workshop is chosen as 3rd choice by maximum 40 respondents.

Table 6.3: Ranked preference for most effective medium for increasing ability and awareness of earthquake risk by the respondents

Mediums	1st preference	2nd preference	3rd preference
Mass media (Television/ Radio etc.)	65	0	0
Newspaper/ Leaflet	0	60	4
Cultural Events (Song/ Play)	1	1	1
Locality based meeting/ workshop	0	2	40
Earthquake training/ drill	0	1	14
Neighbors/ Local residents	0	2	7
Social Media	0	0	0

(Source: Field Survey, 2021)

6.4 Peoples' Perception about Earthquake Vulnerability of the Area

The respondents (household representatives who were interviewed) were asked if they were aware of the earthquake vulnerability of their district. Unfortunately, majority (65%) households (43 of 66 households) do not keep idea about the earthquake vulnerability of their area.

6.4.1 Peoples’ perception regarding earthquake vulnerability of the area from socio-demographic context

Among the household representatives, who answered that they are aware of the earthquake vulnerability of their area (23 of 66 households), 83% are male. From Table 6.4, it can be seen that perception of the respondents about the area being vulnerable is greater among middle aged people compared to others. The awareness level is lower among the young people which should be taken into account to create awareness among them.

Table 6.4: Distribution of household representatives who answered that they are aware of the earthquake vulnerability of their area according to their age

Age Group	Percentage of respondents
Children (<10 years)	0%
Young (11-20 years)	9%
Young Adults (21-30 years)	13%
Middle Aged (31-60 years)	74%
Elderly (> 60 years)	4%

(Source: Field Survey, 2021)

Figure 6.7 shows that the household representatives who are aware of the earthquake vulnerability of their district have a minimum level of educational qualification. The highest percentage (48%) of them has educational qualification up to secondary level, followed by higher secondary level (22%). 17% of them have educational qualification up to post graduate level. Members from these households can easily help as a strong workforce in disaster management activities through awareness building and proper training to enhance earthquake resilience of the community.

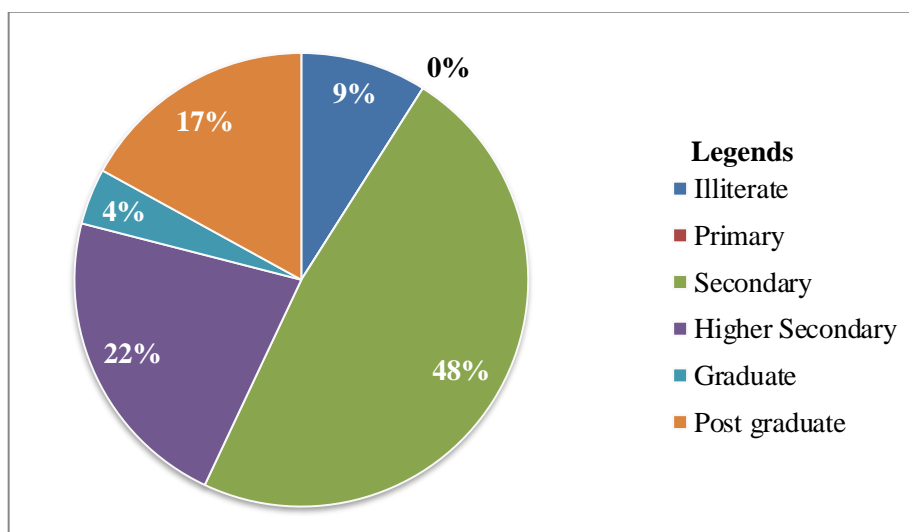

Figure 6.7: Distribution of household representatives who are aware of the earthquake vulnerability of their area according to educational qualification

(Source: Field Survey, 2021)

6.4.2 Peoples' perception regarding earthquake vulnerability of the area with respect to duration of stay

From previous discussion it is evident that, 35% (23 of 66) respondents know about the earthquake vulnerability of their area. It can be assumed that people living in the locality longer period of time are more aware of the vulnerability of the area due to earthquake. However, it was found that there is no relationship between living in the area and awareness of the earthquake vulnerability (Table 6.5).

Table 6.5: Distribution of respondents according to their perception regarding earthquake vulnerability of the area and duration of stay

Duration of stay	Perception		Total
	Area vulnerable to earthquake	Area not vulnerable to earthquake	
1 to 5 years	4.5%	9%	13.5%
5 to 10 years	11%	0%	11%
10 to 15 years	4.5%	6%	10.5%
15 to 20 years	3%	6%	9%
More than 20 years	12%	44%	56%
Total	35%	65%	100%

(Source: Field Survey, 2021)

6.4.3 Reasons behind earthquake vulnerability of the area according to the respondents

When respondents were asked about the reasons of the earthquake vulnerability of the area, they have mentioned the reasons in the orders shown in Figure 6.8.

Geographical condition has been ranked as the first reasons by highest number of respondents (19). Geological condition (type and nature of soil) in the area has been identified as the 2nd reason by maximum 19 respondents and unplanned settlement is chosen as 3rd reason by maximum 16 respondents.

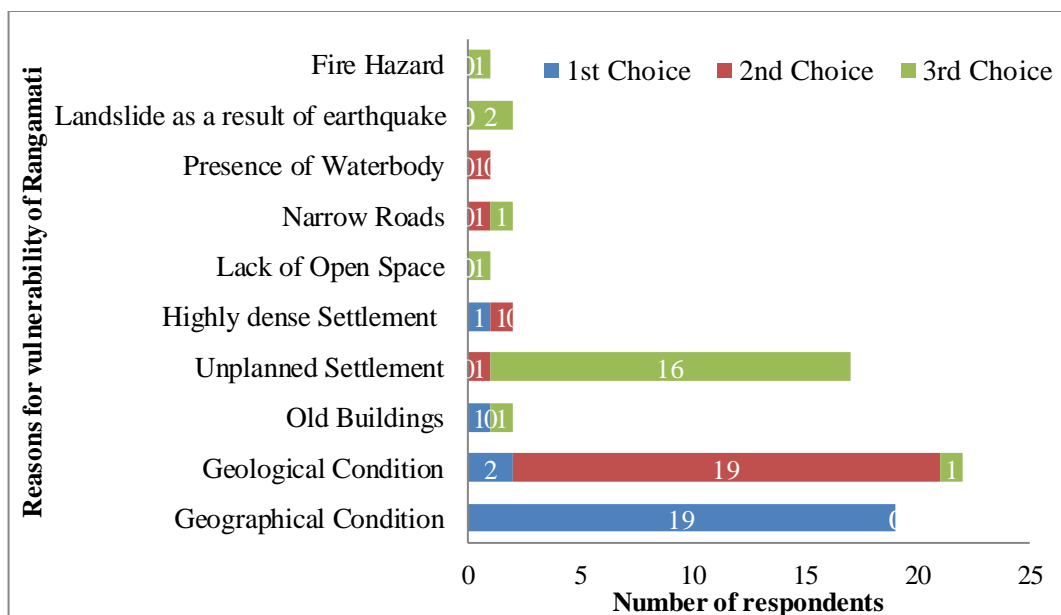

Figure 6.8: Ranked reasons of earthquake vulnerability of the area according to the respondents

(Source: Field Survey, 2021)

6.5 Peoples' Perception about Earthquake Vulnerability of their Building

From previous discussion it is found that, 23 out of 66 (35%) respondents know about earthquake vulnerability of the area. But when respondents were asked whether they knew about the earthquake vulnerability of their own buildings, only 14% (9 out of 66 households) of the respondents thought that they consider their buildings to be vulnerable to earthquake.

6.5.1 Peoples' perception about earthquake vulnerability of their building with respect to land ownership status and duration of stay

Among them 4 are the owners of the buildings and the rest are the tenants and others. However, it can be assumed that people living for longer period of time in the area are more aware of the vulnerability of their buildings due to earthquake. But, from table 6.6, it can be seen that there is a little or no relationship between resident's perception about earthquake vulnerability of their building and their duration of stay.

Table 6.6: Distribution of respondents according to their perception about earthquake vulnerability of their building and their duration of stay

Perception Duration of stay	Building vulnerable to earthquake	Building not vulnerable to earthquake	Total
1 to 5 years	0%	13.5%	13.5%
6 to 10 years	2%	9%	11%
11 to 15 years	0%	10.5%	10.5%
16 to 20 years	0%	9%	9%
More than 20 years	12%	44%	56%
Total	14%	87%	100%

(Source: Field Survey, 2021)

6.5.2 Reasons behind earthquake vulnerability of buildings according to the respondents

When the respondents were asked about the reasons behind earthquake vulnerability of buildings, some reasons have been identified in ranked order (Figure 6.9). Highest number of respondents (7) chose old buildings as the most responsible for earthquake vulnerability of their buildings. Low quality construction materials and techniques, visible cracks in the buildings, the soil type below the building etc. are the other important reasons.

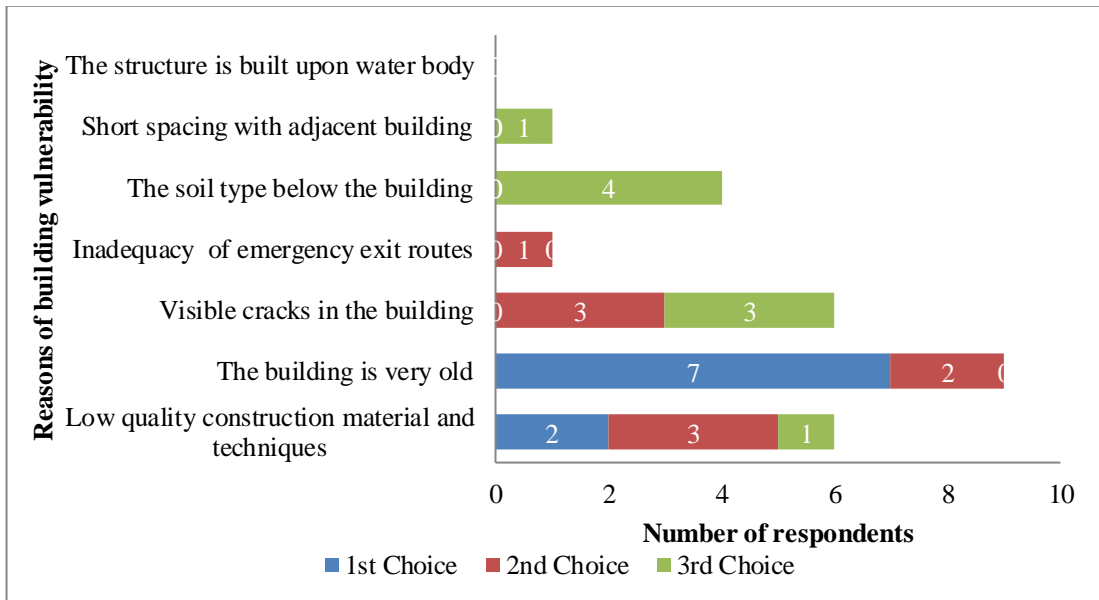

Figure 6.9: Ranked reasons of earthquake vulnerability of the buildings according to the respondents

(Source: Field Survey, 2021)

6.6 People’s Perception Regarding Earthquake Response

During earthquake, the knowledge of emergency response is helpful for the people to save themselves. In this study, it has been tried to understand the knowledge of respondents about the safety precaution one needs during and after earthquake.

6.6.1 Experience and Response of the Respondents to Earthquake

From field survey it has been found that, 61% of the respondents have experienced earthquake. From Figure 6.10, it can be seen that majority of the respondents has last experienced earthquake in 2015 and 2020.

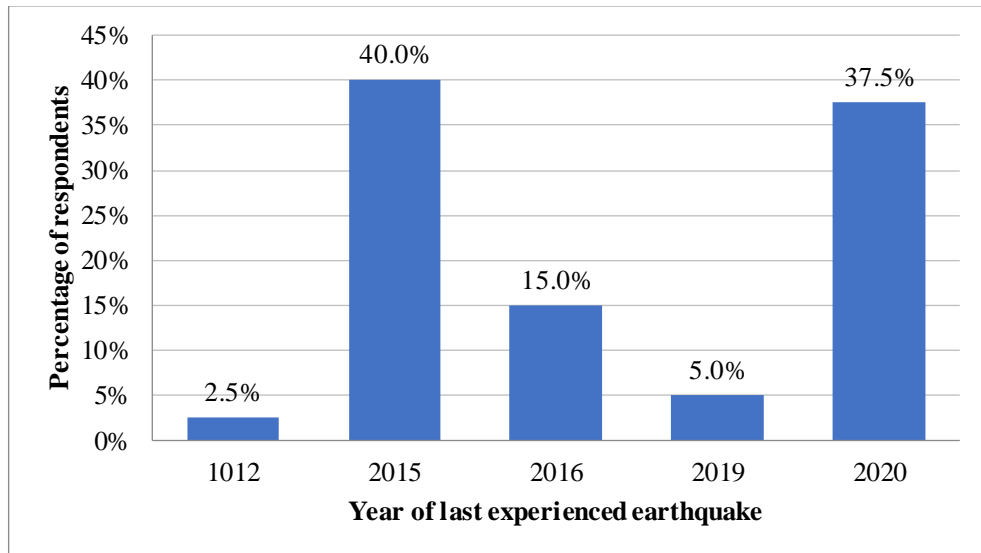

Figure 6.10: Last year when respondents experienced an earthquake
(Source: Field Survey, 2021)

From Figure 6.11 it is visible that, 90% of the respondents who have experienced earthquake went to a safe place (Road) with family during the earthquake. 7.5% of the respondents got panicked. Such response may require concern because they either don't know what to do during earthquake or got panicked and showed no response.

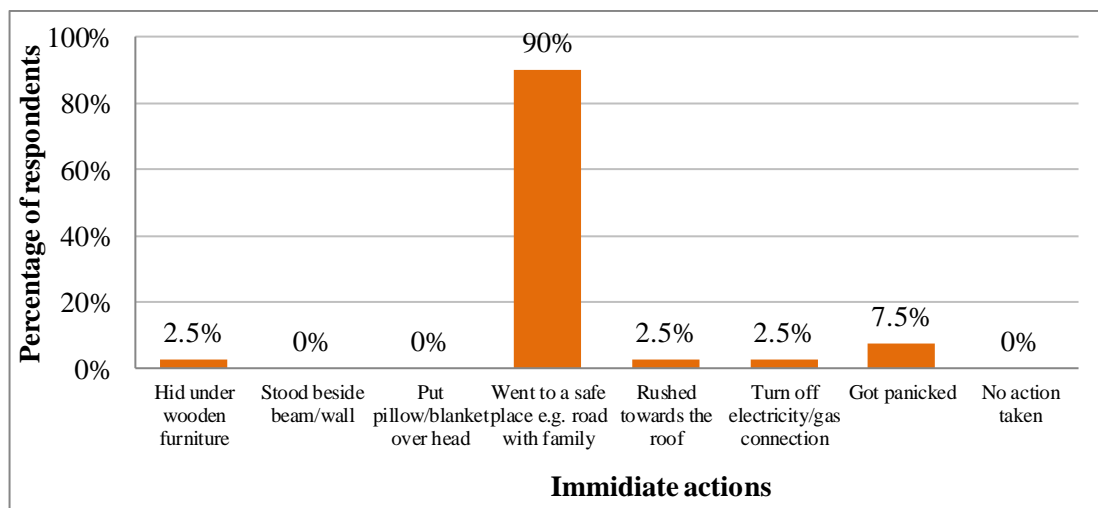

Figure 6.11: Distribution of actions that has been taken during earthquake according to the respondents
(Source: Field Survey, 2021)

6.6.2 People's perception and preference regarding temporary shelter

Earthquake may result in collapse of vulnerable buildings or cracks in buildings. Such buildings require retrofitting and/or reconstruction which can't be done overnight.

Thus, as a result of earthquake, building structures may collapse or become damaged. In this context people should not be allowed to stay there anymore and are needed to move to temporary shelter. Thus the dwellers would need to move to temporary shelter. This study also explored the willingness of respondents to go to temporary shelter during disaster.

When the respondents who are aware of earthquake vulnerability were asked whether they were interested in going to temporary shelter, only 9.1% (6 of 66) responded positively.

Though a low percentage of the respondents showed their willingness to go to temporary shelter, it is still important to know which place they prefer most as temporary shelter. They were asked to rank different options, including open space, playground, educational institution, religious institution and government institution. When the ranking of these options have been done, it is seen that the highest number of respondents prefers educational institutions as their first preferred temporary shelter. As their second choice, government institutions were chosen.

6.7 People's Overall Preparation for Earthquake

It is important to know whether the people have any preparation for earthquake within their family. When respondents were asked about their family preparation for earthquake, only 4 out of 66 of the households responded positively. The preparations taken by these households include assembling some emergency equipment for immediate use and carrying; designating a relatively safe indoor place to stay during earthquake; discussing with family members what to do if earthquake occurs and discussing with the neighbor and other people of the building.

6.8 People's Eagerness to Participate in Disaster Management

Activities

Participation of community people in any disaster related activities is necessary for effective disaster management plan. Community level participation helps integrating with national and international level complement which is very important to ensure proper management after earthquake.

6.8.1 Peoples' willingness to get involved in disaster management related activities of ward

When the respondents were asked their interest to get involved in disaster management work, only 5% (3 out of 66) respondents showed their interest to get involved. So, if WDMC arranges incentive measures to encourage more people in disaster management work and makes provision of training and assistance for the interested people, they can be of great help during the disaster.

6.8.2 Peoples' willingness to work as a volunteer

In disaster management, volunteers are engaged in various activities during pre and post disaster periods. During or after earthquake it is very important to have local volunteer for temporary mission as they know very well about the residents of the area. Unfortunately, when respondents were asked, only 7 out of 309 household members were found who are willing to work as volunteer. No other members are interested in volunteering. So, some incentive measures to encourage the residents in volunteering activities are also required. If they are provided with proper.

6.9 Perception of Owners about Investment for Building Strengthening

From building vulnerability assessment it has been found that a number of buildings in the study area are vulnerable to earthquakes (Chapter Four). To ensure safety of the residents, these buildings should be subjected to emergency retrofit. Strengthening buildings will require owners' knowledge about building vulnerability and willingness for financial investment.

6.9.1 The willingness of the owners to invest in building strengthening with respect to their perception of building vulnerability

It has been found that 36% of building owners (15 of 42) are willing to invest money for building strengthening if their buildings have been found vulnerable. On the other hand, 27 owners are not willing to invest money. From Table 6.7 it can be seen that among 42 owners, 4 of them who have knowledge about their buildings being vulnerable are willing to invest money for building strengthening. On the other hand, 11 owners who do not have any knowledge about building vulnerability are willing to

invest money as well. It can also be seen that 27 owners who are not aware of their building vulnerability are also not willing to invest money.

Table 6.7: Willingness of the owners to invest for strengthening building with respect to their perception about the building being earthquake vulnerable

Willingness Perception	Willing to invest money for building strengthening	Not willing to invest money for building strengthening	Total
Building vulnerable to earthquake	4	0	4
Building not vulnerable to earthquake	11	27	38
Total	15	27	42

(Source: Field survey, 2021)

6.9.2 Support required by owners for building strengthening

4 of the willing building owners want both financial and technical support from the authority for retrofitting of their building if it would be found vulnerable. 11 owners claimed that they would need only technical support

6.10 Perception about Road Widening

If earthquake takes place, it will be difficult for the residents to evacuate safely. Besides, to prepare for a smooth rescue system emergency vehicles for medical emergency and fire service must have access to the households. But from the field survey of 2021 it has been found that there are many roads which are so narrow to give access to these vehicles and also to evacuate safely. So road widening is required to ensure the safe evacuation and rescuing of residents of study area. When the owners of the buildings were asked if they are interested to give away a portion of their land so that the adjacent road of their building can be widened, unfortunately, only 1(2.4%) out of 42 owners showed interest to give their land to widen road.

CHAPTER 7 : CONTINGENCY PLAN FOR EARTHQUAKE IN THE STUDY AREA

7.1 Introduction

In this chapter, the preliminary earthquake contingency plan prepared to reduce the seismic vulnerability of Ward No. 4 of Sunamganj Pourashava has been discussed. The aspects which were intended to consider are:

- Temporary shelter: A place for peoples' temporary displacement caused by a disaster (Xu, Okada, Hatayama, & He, 2006; World Bank Institution, 2012).
- Emergency health facility: Formal health services (hospital, clinic etc.) to treat the moderate and severely injured people after an earthquake (CDMP, 2009).
- Evacuation route: Safe routes in an area for immediate transfer of victims to safer places and shelters, take the injured to health facilities and to transfer relief to the temporary shelters and emergency health facilities after an earthquake (Argyroudis, Pitilakis & Anastasiadis, 2005).
- Ward Co-ordination Center: Central command and control facility responsible for carrying out the principles of emergency preparedness and emergency management or disaster management functions at a strategic level during an emergency, and ensuring the continuity of operation at Ward level.
- Debris Accumulation Point: "Temporary Debris Staging and Reduction Sites (TDRS)" for the accumulation of recyclable debris to designated points in order to prevent obstacle to search-rescue, recovery and relief activities after the disaster (Ministry of Disaster Management and Relief, 2015).

7.2 Temporary Shelter Planning

Temporary shelter planning for the earthquake in the study area of Ward No. 4 of Sunamganj Pourashava will be done first, and then demand for temporary shelter will be estimated. After estimation, demand and supply of temporary shelter in the study area will be compared to understand deficiency or surplus. In the case of the draft

report, only the existing and supply side scenario has been calculated. The findings are discussed here.

For Ward No. 4 of Sunamganj Pourashava, the demand population for temporary shelter is 3368, which means 3368 people would require temporary shelter in the scenario of structural damage due to the earthquake.

It is evident from prevailing literature that large-park, playground and open space, and religious, educational and public buildings are used as temporary shelter (Xu, Okada, Hatayama, & He, 2006; World Bank Institution, 2012). Additionally, from household questionnaire survey, it has been found that residents of this area prefer open space, playfield, government buildings, educational facilities, socio-cultural and urban service-related community facilities as temporary shelter. Thus, the open spaces and facility buildings (i.e., religious, educational institutions, socio-cultural and urban service related community facilities) have been considered to be used as temporary shelter in the study area.

Accordingly, the sites of temporary shelters were identified considering the preference of the residents and using the data extracted from land use map. The locations of temporary shelter were then finalized (figure 7.1) during the consultation workshop with the local people. Among the locations primarily proposed using the land use map, after validation one of the open spaces, “Zila Parishad Playground”, identified as temporary shelter had to be deleted as it coincided with the site chosen for debris accumulation by the local people.

Among the facility buildings identified to be used for temporary shelter, some are structurally vulnerable (with RVS score less than 1.2) which cannot be utilized as temporary shelter. Figure 7.2 shows location of possible temporary shelters in the study area considering safety including the open spaces, safe public buildings, and unsafe public buildings. Table 7.1 shows the supply scenario of the possible temporary shelters in the study area including supply as a whole, capacity of safe facilities and capacity of unsafe facilities.

The local people at the workshop had informed that during heavy rain, the area becomes flooded and the first floors of the structures become water logged. Table 7.1

shows the supply scenario of the possible temporary shelters in the study area including supply as a whole, capacity of safe facilities and capacity of unsafe facilities considering dry season. Table 7.2 shows the similar scenario for rainy season. From Figure 7.2 and Table 7.1 it can be observed that most of the public buildings with higher capacity in the study area are unsafe.

5757 people can be accommodated in the safe buildings and 9628 people can be accommodated in the open spaces of this ward during dry season (Table 6.1). The scenario also indicates that capacity can be increased if unsafe facility buildings are retrofitted. If the unsafe buildings were retrofitted, they would be able to accommodate 1643 more people in the dry season. This will be useful if the adjacent wards face shortage of required shelter facilities in their own wards.

From Table 7.2, it can be seen that 2490 people can be accommodated in the safe buildings during rainy season, which fails to meet the shelter demand of the ward and is insufficient according to the demand scenario. If the unsafe buildings were retrofitted, they would be able to accommodate 762 more people, being able to just meet the shelter demand. Thus, the unsafe facility buildings must be urgently retrofitted.

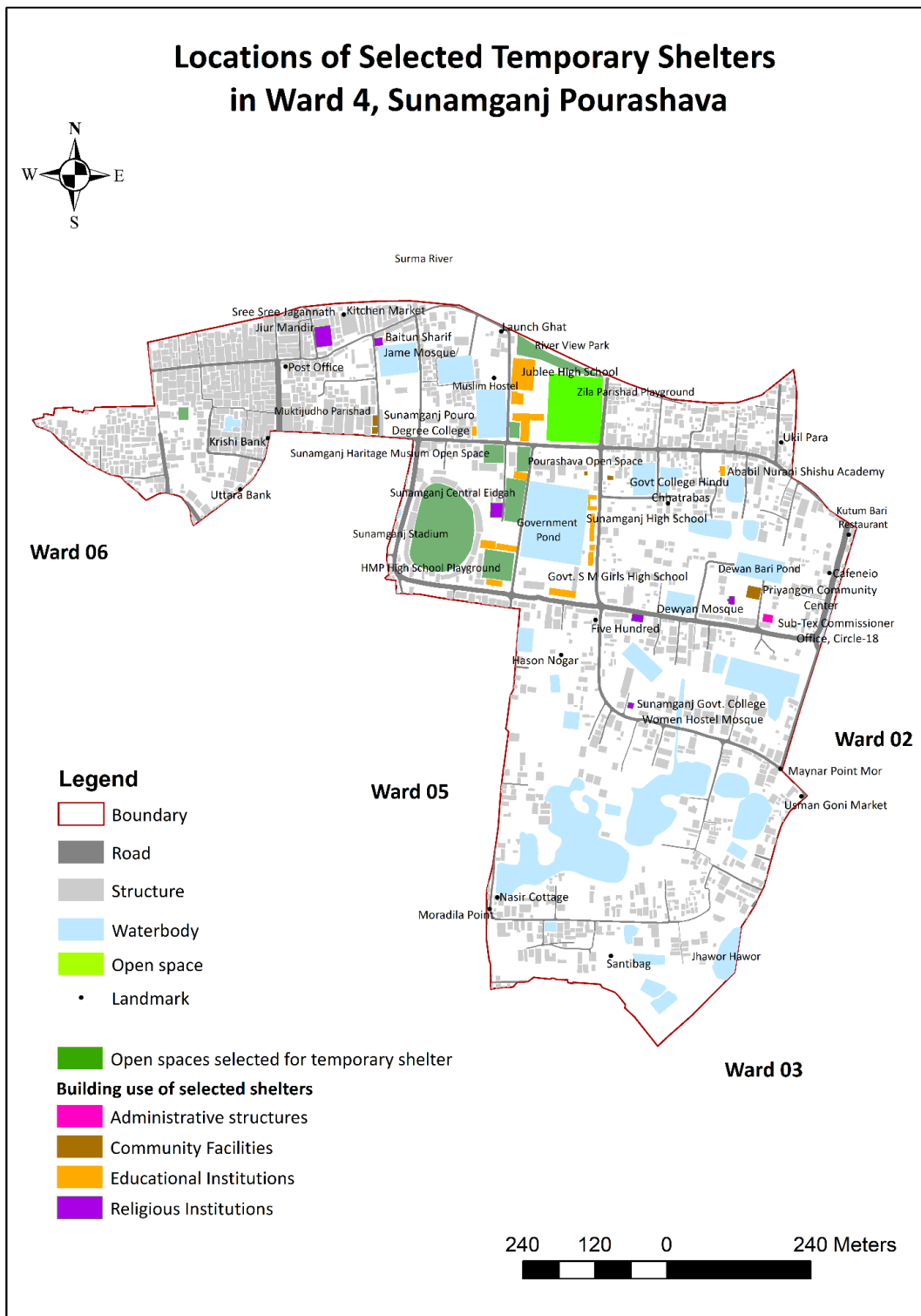

Figure 7.1: Location of selected temporary shelter in the study area
(Source: Field Survey, 2021)

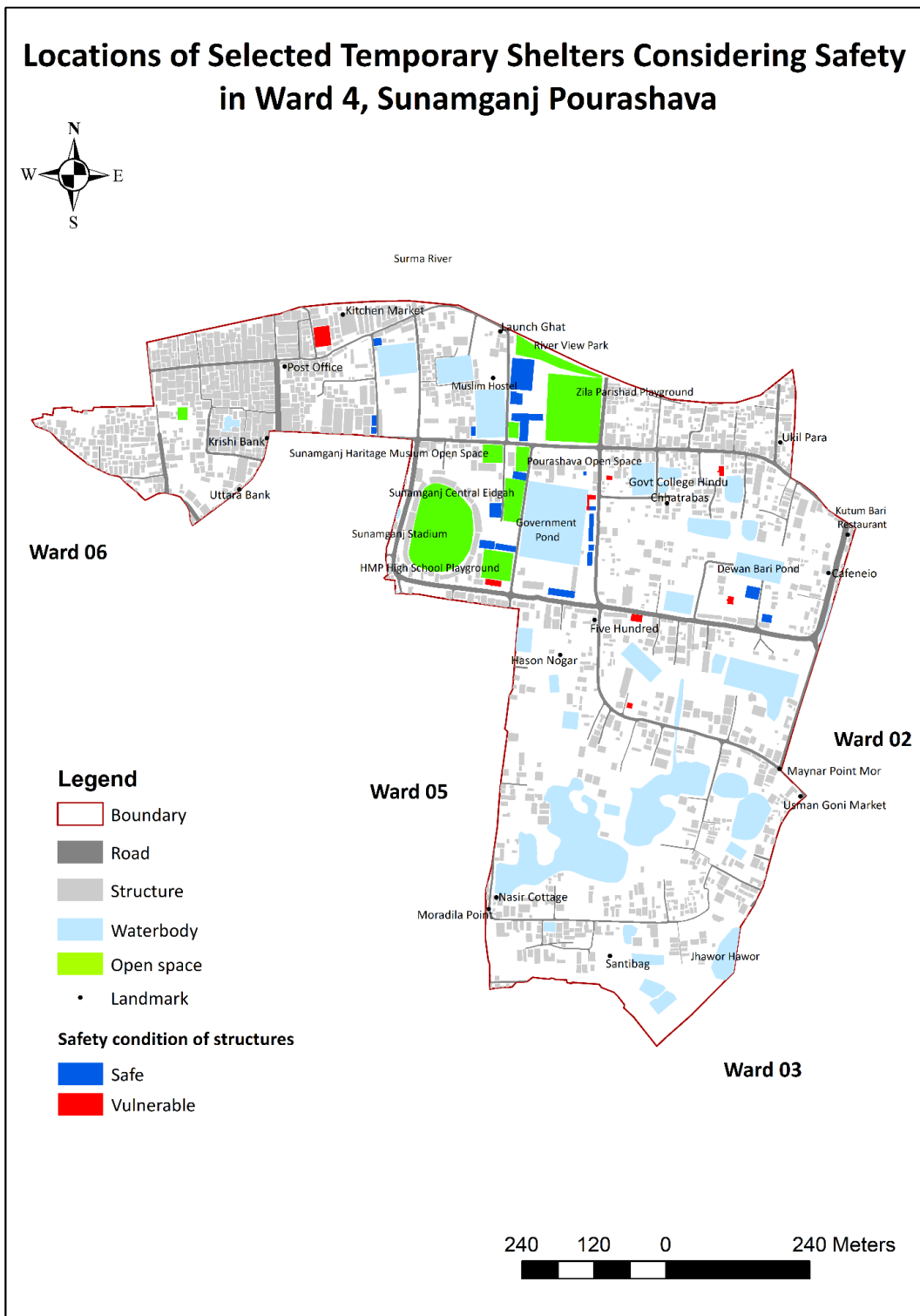

Figure 7.2: Location of selected temporary shelter in the study area considering safety
(Source: Field Survey, 2021)

Table 7.1: Supply scenario of the possible temporary shelters in the study area considering dry season

Type	Total			Safe facilities			Unsafe facilities		
	Number of facilities	Area to be used for shelter purpose (sq. m.)	Capacity (no. of people)*	Number of facilities	Area to be used for shelter purpose (sq. m.)	Capacity (no. of people)*	Number of facilities	Area to be used for shelter purpose (sq. m.)	Capacity (no. of people)*
Open spaces	8	17331.448	9628	8	17331.448	9628			
Educational Institution	16	9206.56	5114	12	8176.53	4542	3	1029.95	572
Religious Institution	6	2762.65	1534	2	888.335	493	4	1874.315	1041
Administrative Institutions	1	513.055	285	1	513.055	285	0	0	0
Community Facility	5	842.000	467	4	787.829	437	1	54.171	30
Total	35	30655.713	17028	27	27697.197	15385	8	2958.436	1643

(Source: Field Survey, 2021)

*1.8 m² in shelter is required per person according to Sphere Project (2011)

Table 7.2: Supply scenario of the possible temporary shelters in the study area considering rainy season

Type	Total			Safe facilities			Unsafe facilities		
	Number of facilities	Area to be used for shelter purpose (sq. m.)	Capacity (no. of people)*	Number of facilities	Area to be used for shelter purpose (sq. m.)	Capacity (no. of people)*	Number of facilities	Area to be used for shelter purpose (sq. m.)	Capacity (no. of people)*
Open spaces	8	0	0						
Educational Institution	12	4128.80	2293	10	3569.84	1983	2	558.96	310
Religious Institution	3	1190.95	661	1	376.188	208	2	814.762	452
Administrative Institutions	1	342.037	190	1	342.037	190	0	0	0
Community Facility	2	197.329	109	2	197.329	109	0	0	0
Total	18	5859.116	3253	14	4485.394	2490	4	1373.722	762

(Source: Field Survey, 2021)

*1.8 m² in shelter is required per person according to Sphere Project (2011)

7.3 Emergency Health Facility Planning

A considerable number of people would be injured in an earthquake. Considering the assumptions mentioned in Chapter-2, Volume-1, a possible number of injured people in the study would be calculated corresponding to different severity level, which is shown in Table 7.3.

Among the probably injured persons, Severity 1 can be treated in pharmacies or by primary treatment experts in a temporary shelter without being admitted to hospital. However, the people with higher-level injury (Severity 2 and Severity 3) need treatment from experts in health facilities. Injured people of Severity 4 will be instantaneously killed or mortally injured, for whom further expertise treatments will be required. Thus, total 210 injured people (Severity 2, 3 and 4) will be required to be admitted to the health facilities.

Table 7.3: Need of emergency health facilities in the study area

Total Popⁿ	Injured people: Severity 1	Injured people: Severity 2	Injured people: Severity 3	Injured people: Severity 4
9192	243	120	30	60

Source: Calculation based on Field Survey, 2021

The emergency health facilities were identified as per the requirement mentioned in Chapter-2, Volume-1. The locations of the health facilities were then finalized during the consultation workshop with the local people. These facilities include hospital, diagnostic centre and clinics and pharmacies which might be used for giving first aid treatment for injured people of severity 1 as shown in Figure 7.3.

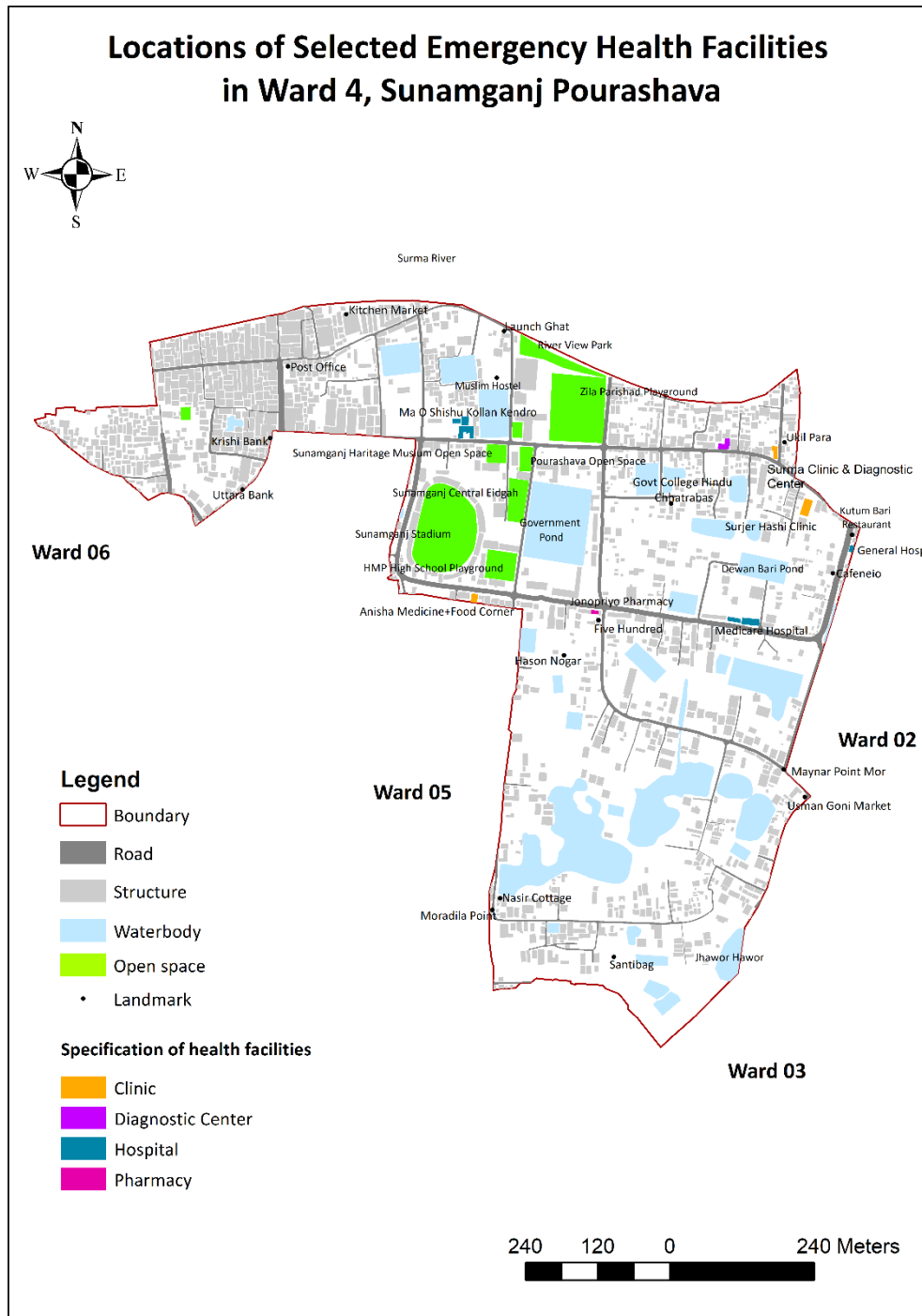

Figure 7.3: Location of selected emergency health facilities in the study area

(Source: Field Survey, 2021)

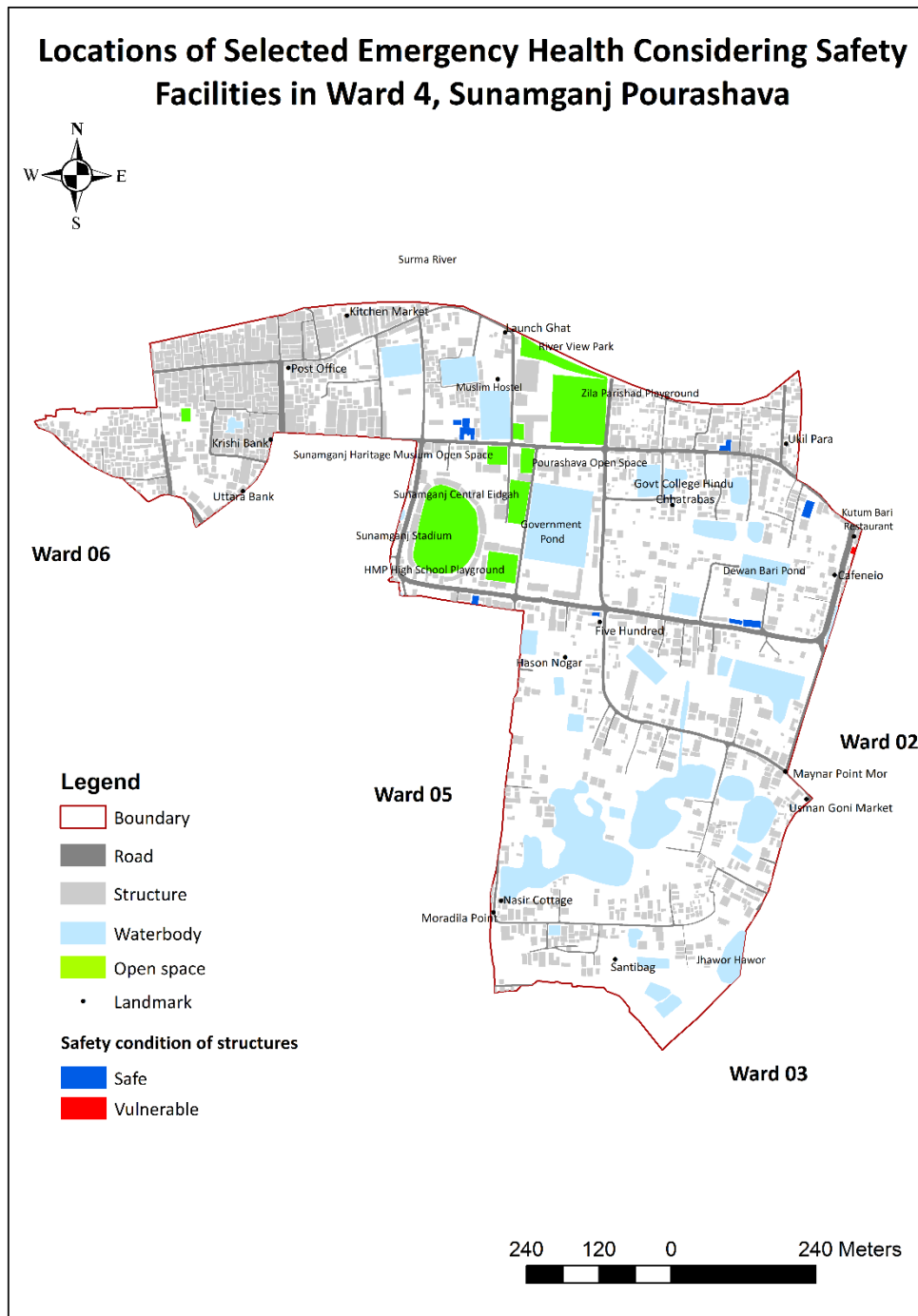

Figure 7.4: Location of selected emergency health facilities in the study area considering safety
(Source: Field Survey, 2021)

Table 7.4: Supply scenario of the possible emergency health facilities in the study area considering dry season

Type	Total			Safe facilities			Unsafe facilities		
	Number of facilities	Area to be used for shelter purpose (sq. m.)	Capacity (no. of people)*	Number of facilities	Area to be used for shelter purpose (sq. m.)	Capacity (no. of people)*	Number of facilities	Area to be used for shelter purpose (sq. m.)	Capacity (no. of people)*
Pharmacy	1	63.1988	31	1	63.1988	31	0	0	0
Hospital	6	1948.09	974	5	1696.054	848	1	252.036	126
Clinic	3	1984.58	992	3	1984.58	992	0	0	0
Diagnostic Centre	1	578.316	289	1	578.316	289	0	0	0
Total	11	4574.185	2286	10	4322.149	2160	1	252.036	126

Source: Field Survey, 2021

* 2 m² in shelter is required per person according to Sphere Project (2011)

Table 7.5: Supply scenario of the possible emergency health facilities in the study area considering rainy season

Type	Total			Safe facilities			Unsafe facilities		
	Number of facilities	Area to be used for shelter purpose (sq. m.)	Capacity (no. of people)*	Number of facilities	Area to be used for shelter purpose (sq. m.)	Capacity (no. of people)*	Number of facilities	Area to be used for shelter purpose (sq. m.)	Capacity (no. of people)*
Pharmacy	0	0	0	0	0	0	0	0	0
Hospital	4	959.963	479	3	770.936	385	1	189.027	94
Clinic	3	1409.58	704	3	1409.58	704	0	0	0
Diagnostic Centre	1	385.544	192	1	385.544	192	0	0	0
Total	8	2755.087	1375	7	2566.06	1281	1	189.027	94

Source: Field Survey, 2021

* 2 m² in shelter is required per person according to Sphere Project (2011)

Capacity of the health facilities are calculated here for two scenarios. First, there has been considered only structurally safe health facility buildings. In second, structurally unsafe health, facility buildings were taken into account. If only safe buildings could not meet the demand, then selected unsafe health facility buildings might be retrofitted to equalize the supply and demand. Figure 7.4 shows the emergency health facility buildings according to the structural safety of the facility building. Again, as discussed in section 7.2, the area gets flooded during heavy rain causing first floors to go under water. Thus, considering the assumptions described in methodology chapter (Chapter-2, Volume-1), the capacity of each of the emergency health facilities were determined considering dry and rainy season separately which have been shown in Table 7.4 and Table 7.5 accordingly. They also show number of emergency health facilities and their area and the number of persons they could treat considering the space requirement per person (2 square meters) for both safe and unsafe facility buildings.

It has been found from Table 7.4 that there are three clinics, one diagnostic center, one pharmacy, and six hospitals. Except one hospital buildings, the rest buildings are structurally safe enough to be used as emergency health facilities. 2160 people can be treated at safe health facilities during dry season and 1281 people can be treated there during rainy season at the time of emergency. If the unsafe building could be retrofitted, 126 more people could have been given health service during dry season and 94 more people could have been served during rainy season.

Comparing the probable requirement (Table 7.3) and availability (Table 7.4 and Table 7.5) it can be concluded that existing facilities are sufficient to meet the demand. If the unsafe buildings are retrofitted, the capacity of the emergency health service will be increased which might be useful and serve the surrounding area. Table 7.6 shows the situation between requirement and availability of emergency health facilities in the study area.

Table 7.6: Demand-supply comparison of emergency health facilities in the study area

Demand-supply components	Dry Season		Rainy Season	
	Number of people	Surplus/ Deficit	Number of people	Surplus/ Deficit
Person needed to be treated	210	–	210	–
Person can be treated in safe facilities	2160	1950	1281	1071
Person can be treated if unsafe facilities are retrofitted and added	2286	2076	1375	1165
Remarks	Existing facilities are sufficient to meet the demand.		Existing facilities are sufficient to meet the demand.	

(Source: Calculation based on Field Survey, 2021)

7.4 Evacuation Route Plan

The ward is more dense and urbanized in the northern portion alongside the Surma River. Majority of the access roads have width less than 4 feet, which is generally suitable for walking and one-way, bicycle (Figure: 7.5). Roads with four to eight feet width are scattered around the ward except the middle portion where density of educational and administrative institutions are present in large number. These roads are accessible for one-way rickshaw, van, and two-way motorcycle. Roads, which are wide in 8 to 12 feet, can accommodate two ways for rickshaw, van, motorcycle, and bicycle. These roads are distributed over the ward. Several segments of single carriageway, which has width between 12 to 25 feet is seen in the middle portion of the ward providing access to the educational institutions and public structures of the ward. There is only one segment of road, which has width more than 25 feet and that is marked as two-lane carriageway. This road goes through the middle of the ward connects the ward with the adjacent wards

As most of the roads providing access to the structures are less than 8 feet in width, it creates a concern because in the case of any emergency, most of the roads will not be

accessible by emergency vehicles and ambulances. Besides, roads of lesser width will have higher probability of being blocked by earthquake debris. This information has been depicted from the accessibility map of Figure 7.5.

Figure 7.6 and 7.8 identify the sections of road those would be probably blocked if an earthquake of 7-8 and greater than 8 respectively strikes based on the assumptions described in methodology (Chapter-2, Volume-1). Accessibility of the roads for rescue and rehabilitation were identified considering the road width and blockage size after an earthquake. As pucca and high-rise structures are mainly clustered in the northern portion where density and urbanization is higher, possible blockages of roads are also concentrated in the upper part of the ward. According to the methodology, for a >8 earthquake, two locations might have partial blockage of roads. One of them is very crucial as it blocks the two-lane carriageway. In addition, 11 locations were found where roads might be fully blocked after the earthquake. For a 7-8 earthquake, also two locations might have partial blockage of roads but does not include the two-lane carriageway. Also, 8 locations were found where roads might be fully blocked after the earthquake.

From the maps (Figure: 7.5, 7.6, and 7.8) it can be observed that roads less than 8 feet are mainly prone to blockage. It indicates that rescuing from residential building and access to temporary shelter and emergency health facility and will be quite challenging. The single-lane carriageway, which connects this ward with the surrounding wards, will be fully blocked in at least two locations if a >8 magnitude earthquake strikes. These blockages are crucial, as they will trap other roads which will be unable to use for any kind of movements and which will possibly prohibit entrance of any large emergency vehicle or rescuing equipment in the southern portion of the ward. Figure-7.7 and 7.9 provide the evacuation route maps which will be usable for the evacuees to move to designated locations after an earthquake.

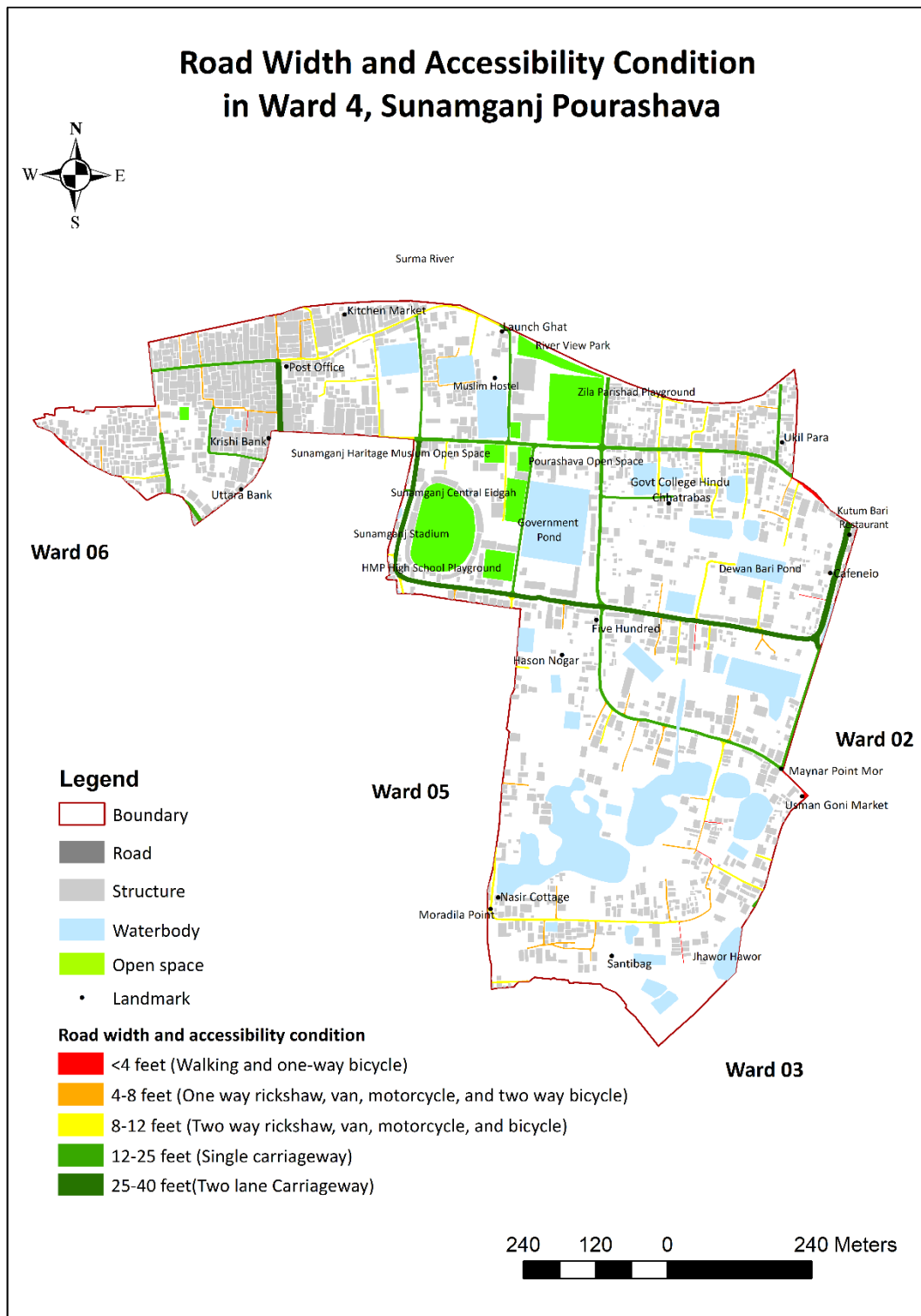

Figure 7.5: Road width and accessibility condition
(Source: Field Survey, 2021)

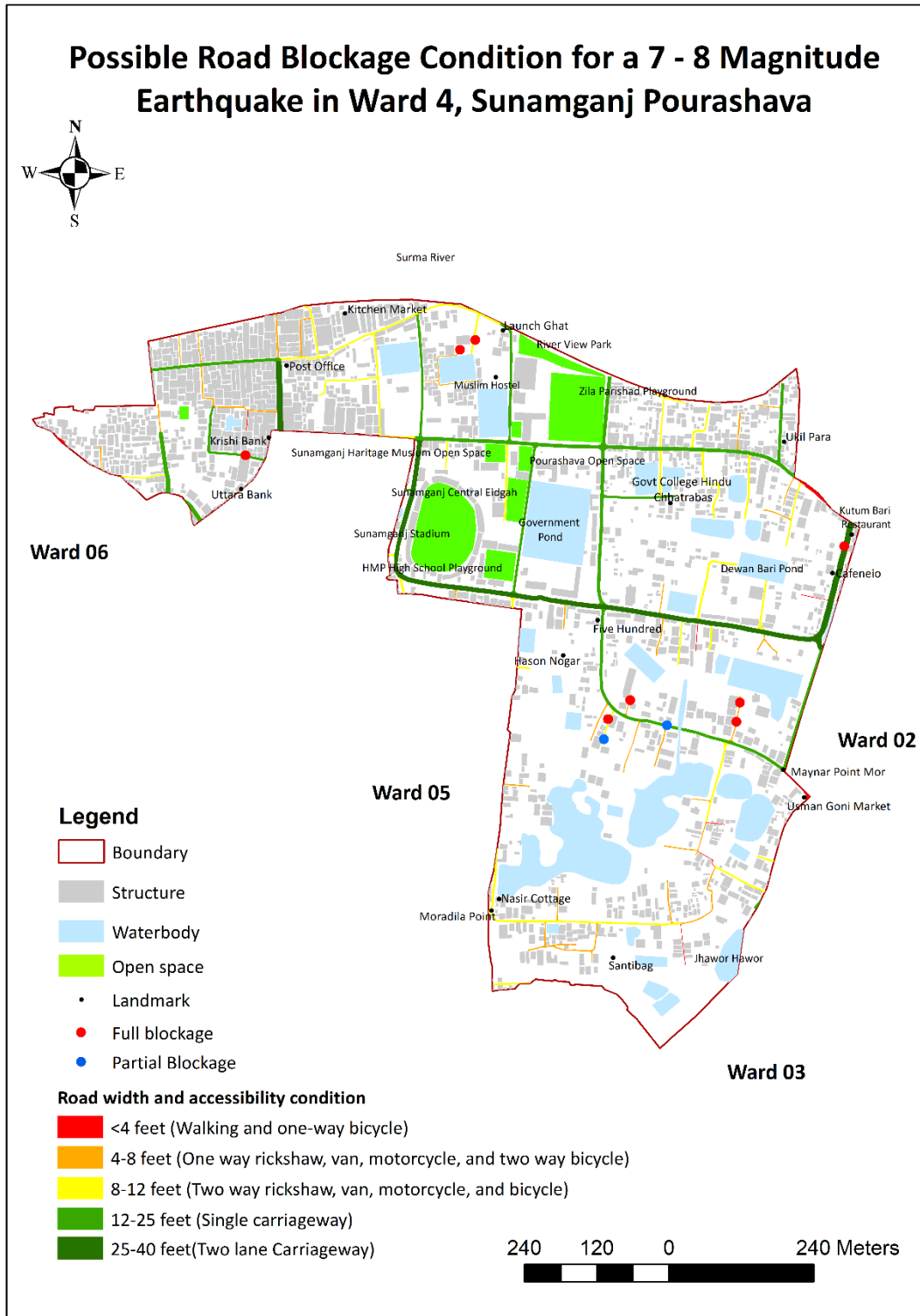

Figure 7.6: Possible road blockage condition for Scenario 01
(Source: Field Survey, 2021)

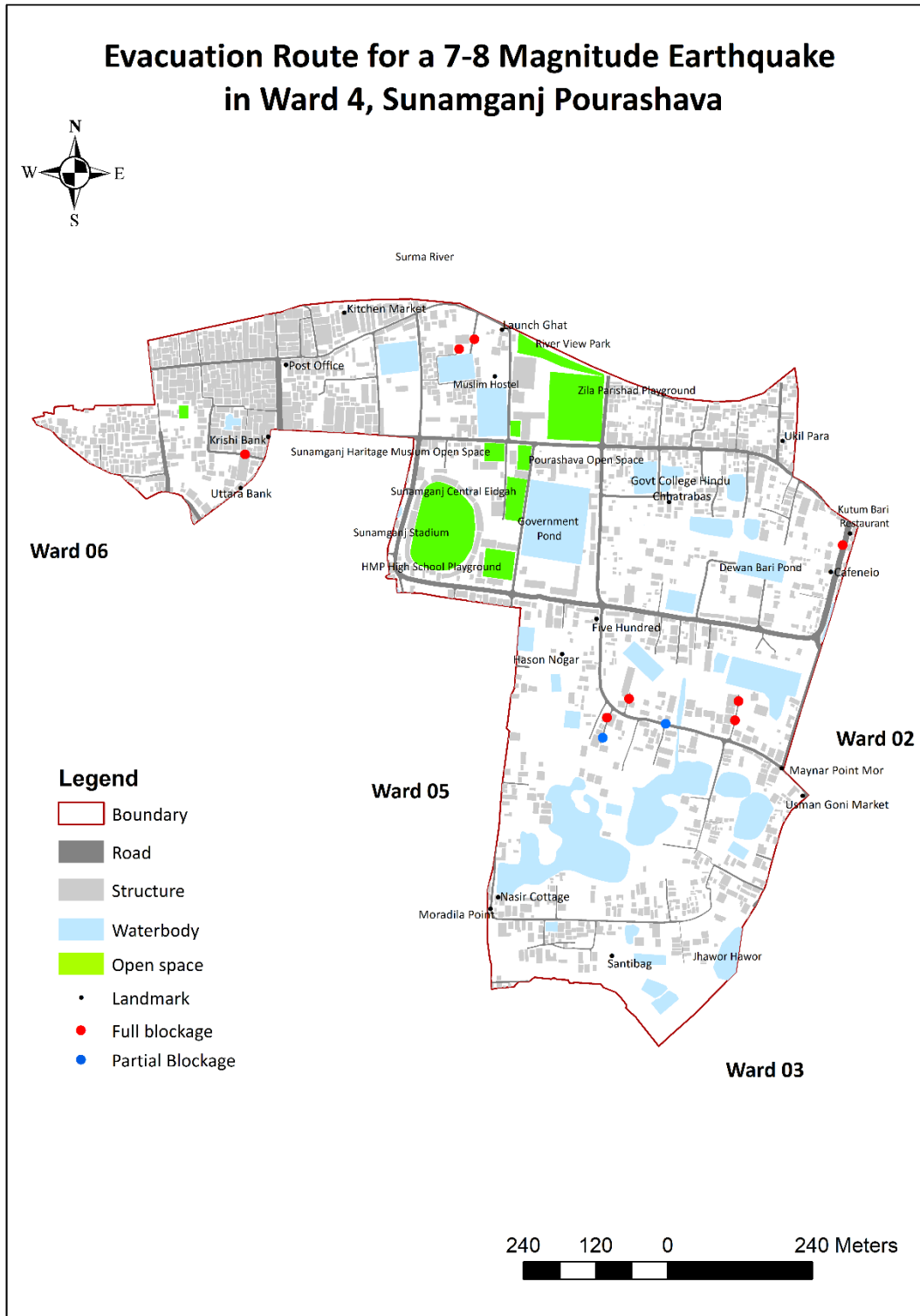

Figure 7.7: Evacuation Route Map for Scenario 01
(Source: Field Survey, 2021)

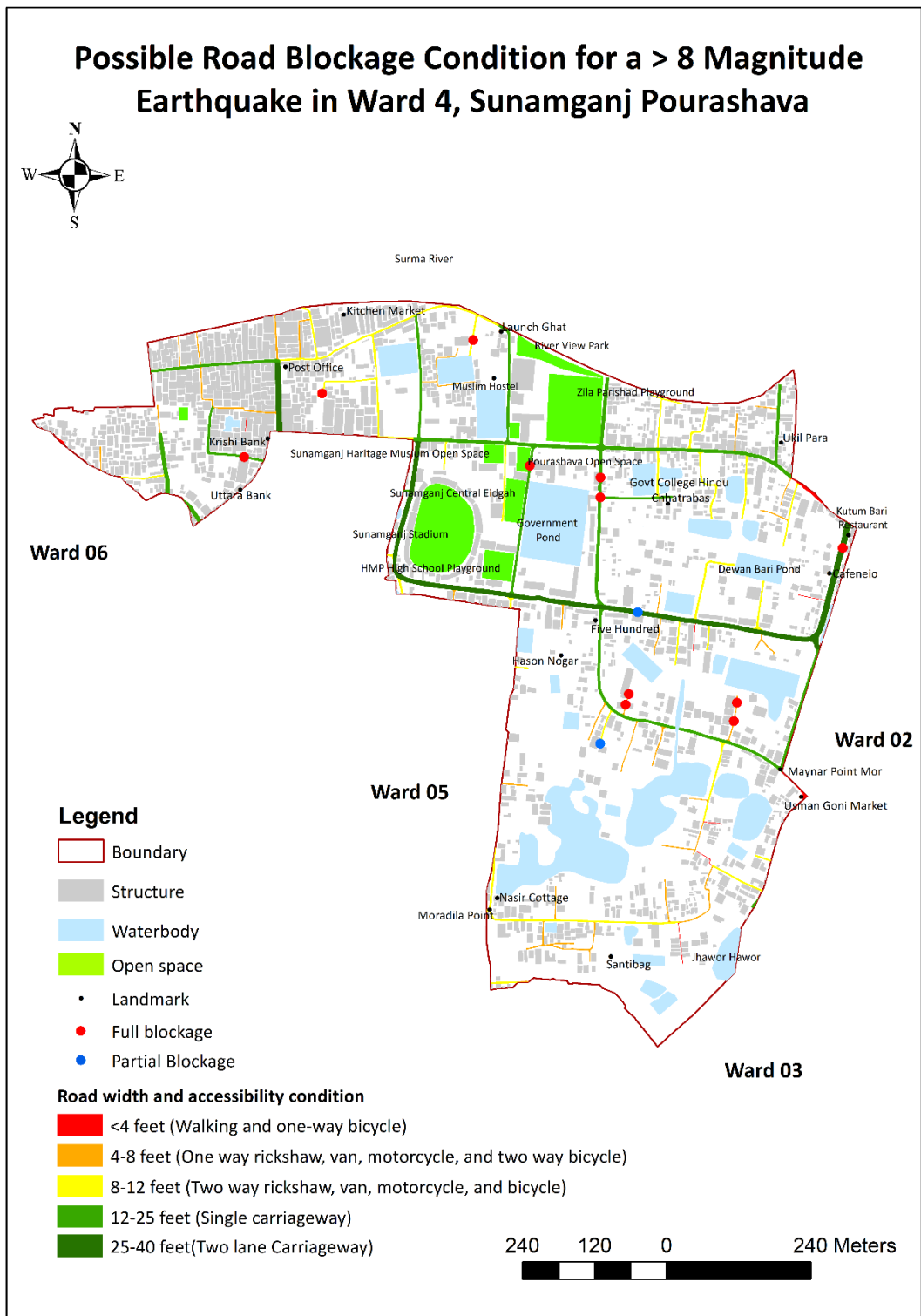

Figure 7.8: Possible road blockage condition for Scenario 02
(Source: Field Survey, 2021)

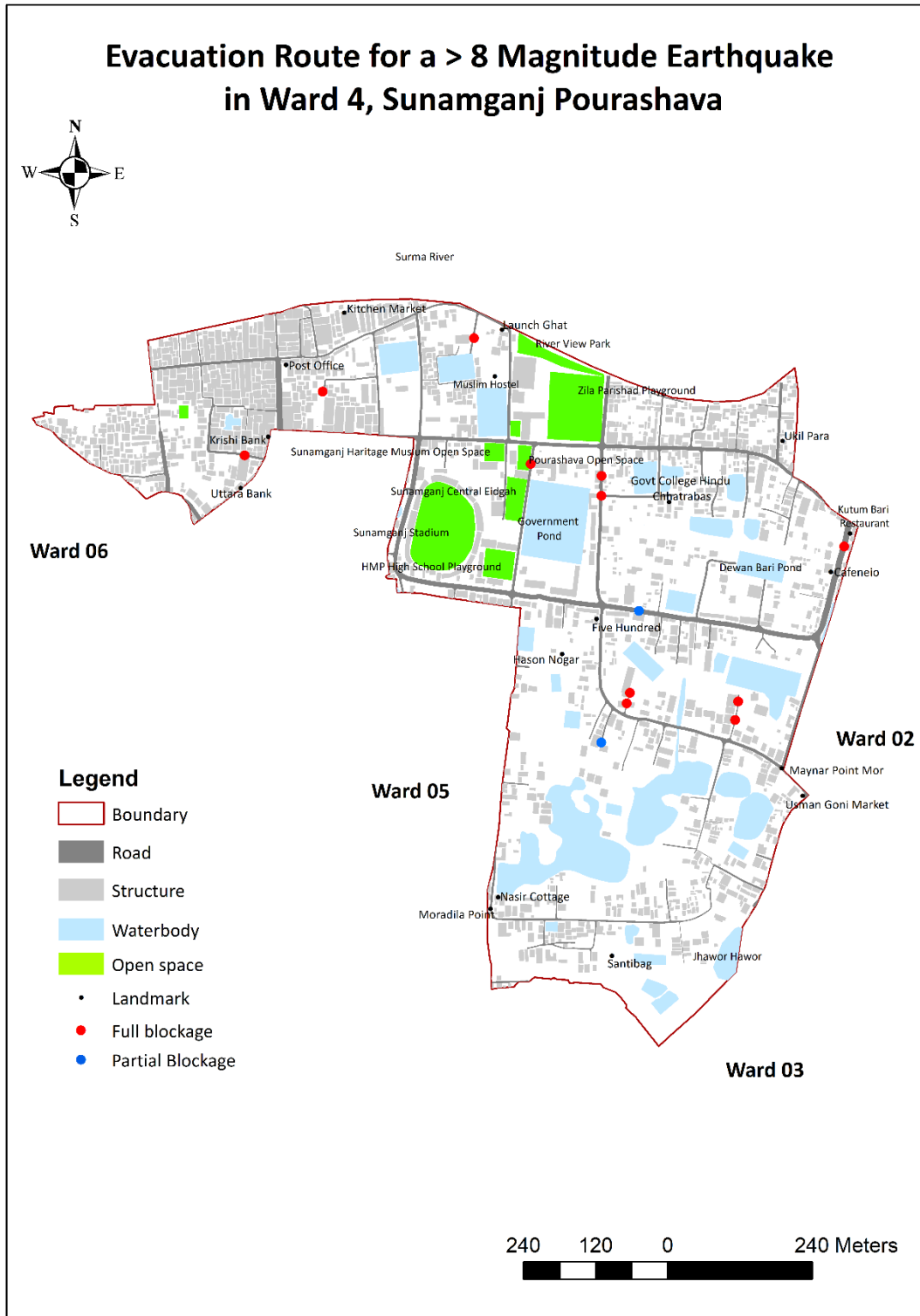

Figure 7.9: Evacuation Route Map for Scenario 02
(Source: Field Survey, 2021)

7.5 Ward Co-ordination Center

One of the important tasks during and after any disaster is to coordinate the different activities of management. Tasks performed by different government agencies, private organizations, volunteers, and individuals are needed to be coordinated to get the maximum benefit. In addition, WDMC needed a place to coordinate the works. For this co-ordination, Ward Co-ordination Center (WCC) is proposed to be formed in the study area. In this section, proposed location for Ward Co-ordination Center has been described.

As mentioned in the methodology, the selection criteria considered in this study for Ward Co-ordination Center are: the facility should be in a government building, should be structurally safe, and should be centrally located and easily accessible (Chapter-2, Volume-1). The building of Govt. S M Girls' High School has been proposed for the establishment of WCC in this ward (Figure: 7.8). The building is a two storeyed public building, which was proven structurally safe according to RVS. The location was chosen in a way so that it could be most distant from the roadblocks. Adjacent road width of the building is more than 25 feet, which is a two-lane carriage way and this long segment of single carriageway connects the location with adjacent wards. Besides, the public open spaces, which could be used as temporary shelter after an earthquake are very close to the structure. Therefore, it can be said that, Govt. S M Girls' High School has met all the location criteria for WCC and is in an optimal position considering safety, accessibility, and centrality. The structure was also validated in the consultation workshop.

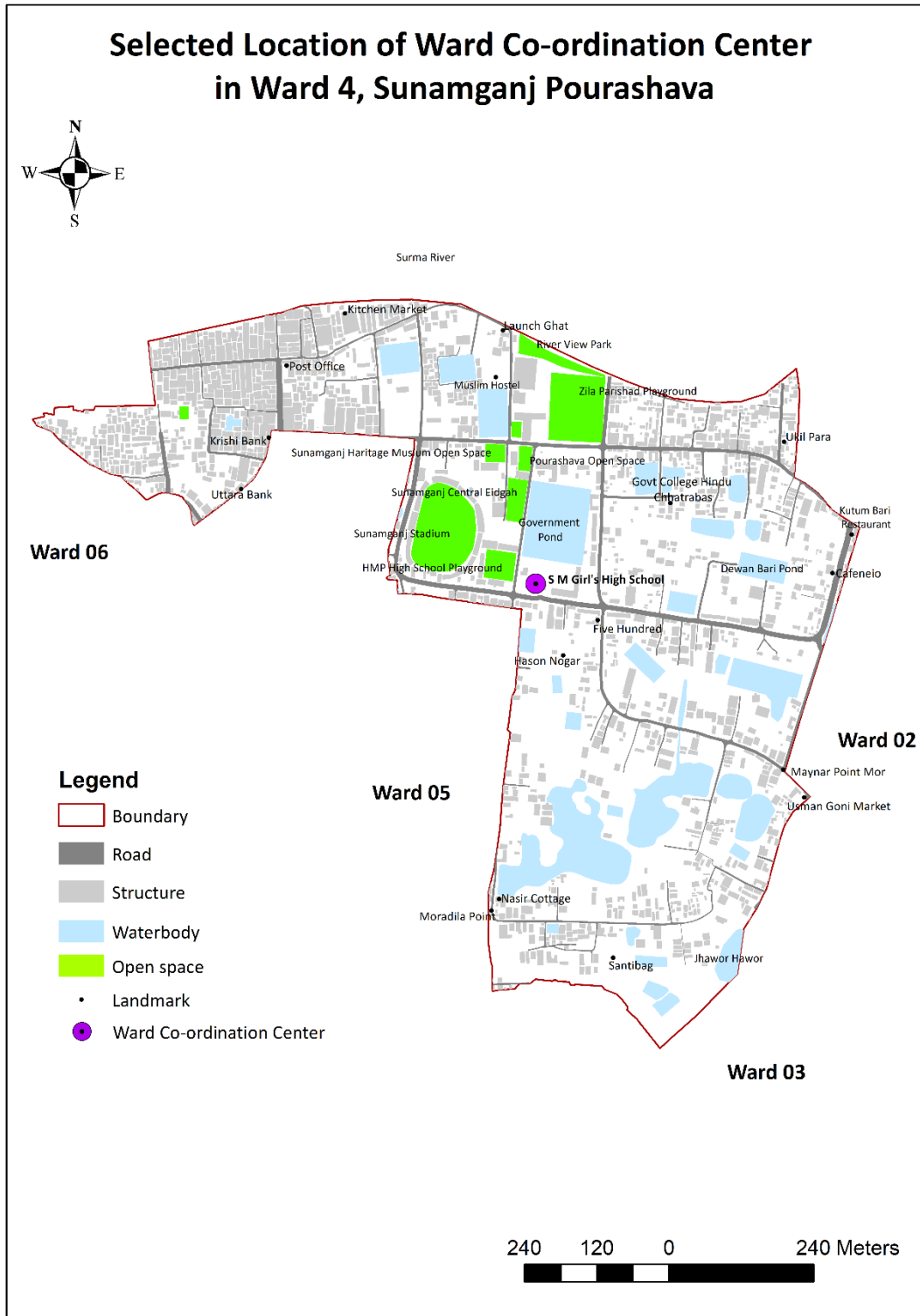

Figure 7.10: Location of selected Ward Co-ordination Center
(Source: Field Survey, 2021)

7.6 Debris Accumulation Point

After an earthquake, building and infrastructure will collapse trapping debris within or outside damaged structure. Again collapse buildings will block the streets which make it difficult to carry out search-rescue, recovery and relief activities. So, identifying accumulation points of debris is essential. As mentioned in the methodology (Chapter-2, Volume-1), non-recyclable debris are to be disposed in the locally authorized landfill or dumpsite while maintaining caution for hazardous debris which have to be disposed of under controlled engineering method. In case of recyclable debris, temporary sites called “Temporary Debris Staging and Reduction Sites (TDRS)” have to be identified following the criteria described in the methodology which has been covered in this section.

Initially, among the designated open spaces in this ward, no open space could be found suitable as a TDRS site. All of them were within 50m distances of nearby water bodies. Again, no vacant land could be identified which may be suitable for this purpose. After consultation with local people, they suggested the ‘Zila Parishad Playground’ on the northern side of the ward for temporary debris accumulation (Figure 7.11). However, those in management must maintain standards and guidelines for ensuring no dumping and mishaps to the waterbodies adjacent to it.

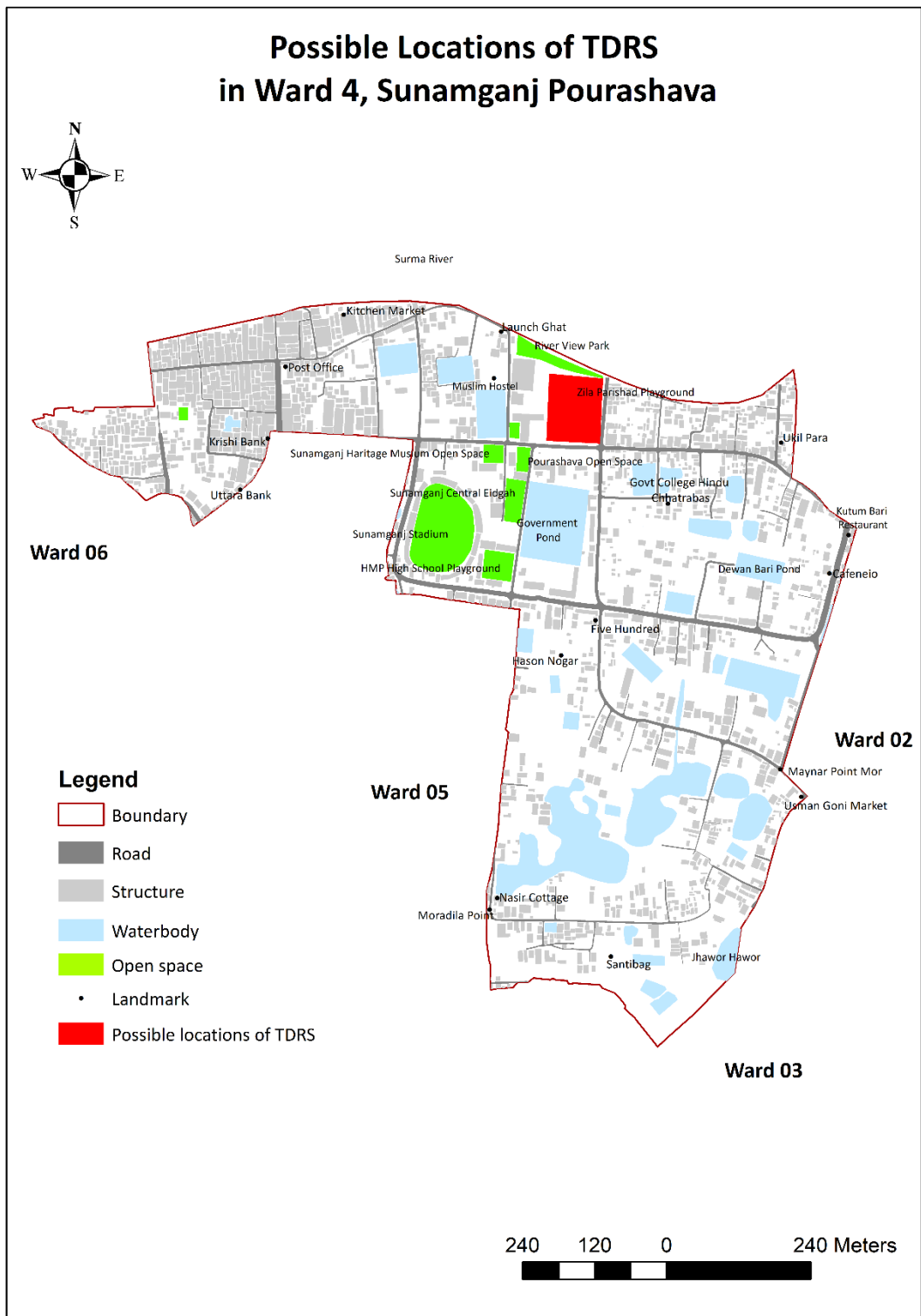

Figure 7.11: Possible locations of TDRS
(Source: Field Survey, 2021)

CHAPTER 8 : IMPLEMENTATION AND MANAGEMENT OF THE CONTINGENCY PLAN

One of the very important tasks during and after any disaster is to coordinate the different activities of management. Tasks performed by different government agencies, private organizations, volunteers, and individuals are needed to be coordinated to get the maximum benefit. For this purpose, according to the Standing Orders of Disaster 2019, broadly two types of committees have been formed at the local level – Disaster Management Committees and Disaster Response Coordination Groups. The tier follows the basic local administrative structure of the country with the Divisional Disaster Management Committee at the top and the ward/union-level committees at the bottom (Figure 8.1). The Disaster Management Committees are responsible for implementing disaster risk reduction functions along with preparedness, emergency response and recovery phase activities. The Disaster Response Coordination Groups act as another umbrella organization to co-ordinate all the small-scale works which will lead to the successful implementation of the complete contingency plan.

The SOD 2019 elaborates on the composition of the aforementioned committees, their compulsory meetings, and their responsibilities and functions. The responsibilities of the Disaster Management Committees have been subdivided as per risk reduction and emergency response functions for pre, during and post disaster stages. Throughout all the stages, it is an imperative responsibility to maintain proper and effective coordination among the committees at different local levels. To reinforce so, the compositions of the committees have been designed accordingly (Appendix B). For instance, the chairpersons of every committee are members of their immediate upper level committee.

As temporary shelters and emergency health facilities are the two major components of the contingency plan, sub-committees with specific list of duties and responsibilities should be formed under the Ward Disaster Management Committee to implement the plan smoothly. The SOD also mentions the formation of sub-committees under the

ward disaster management committees as per required. In this chapter, working procedures and implementing authorities of some necessary committees under this plan have been briefly described.

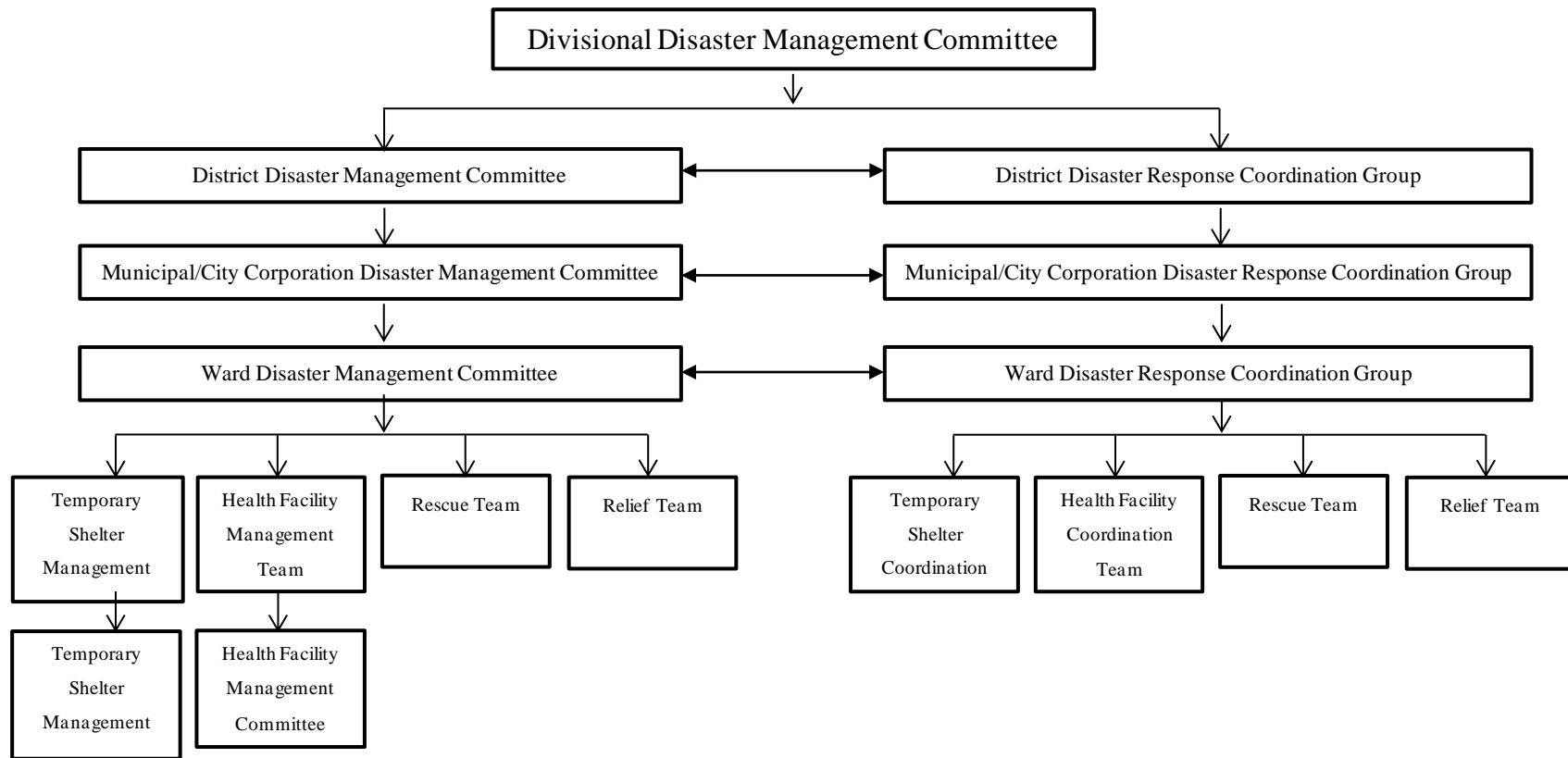

Figure 8.1: The tiers of Disaster Management Committees at local level and the structure of Ward Management Committee

8.1 Activities of Ward Disaster Management Committee at Different Phases of an Earthquake

The composition of WDMC has been detailed in the SOD 2019 (Appendix B). The BUET team suggests the formation of further groups under the WDMC which will work in corporation with it. These are described in the sections ahead. Following the duties and functions of the WDMC outlined in the SOD 2019, the responsibilities/activities of the WDMC have been further detailed and categorized into five phases for specifically in case of an earthquake.

a) Activities before Disaster

- Retrofitting of essential buildings
- A systematic program for the inspection, maintenance, and repair of buildings identified as temporary shelters and emergency health facilities at regular interval at the community level by building maintenance and rehabilitation team
- Storage of equipment and emergency supplies
- Proper dissemination of the prepared plans at the community level by victim registration and information team
- The training program at community level at a regular interval
- The arrangement of community awareness program at a regular interval such as disaster drills, emergency training, community meetings etc.
- Preparation of volunteer list at the community level and updated it at regular interval
- Distribution of activities of volunteers
- Training of volunteers based on their activities
- Identification of the people at risk and categorizing them based on gender, disabilities, age
- Preparation of checklist of emergency activities

b) Activities within 72 Hours of an Earthquake Event

- Evacuation of the people to the predefined evacuation space.

- Ensuring safety of women and children in the shelters by providing separate rooms
- The arrangement of necessary reliefs by the relief management team.
- Search and rescue of people by the search and rescue team.
- Disaster victim registration and segmentation of the victims according to their need for health facility and shelter requirement.
- Assessment of the suitability of the pre-identified temporary shelters and emergency health services by building maintenance and rehabilitation team. If any of the pre-identified temporary shelters and emergency health services are proved unsuitable, then initiative should be taken to identify alternative places to provide temporary shelter and emergency health facility.
- Assessment of the pre-identified evacuation routes (to reach the shelters and health services) to find out whether they are open or not. If required, new evacuation routes should be identified or adjustments should be done.
- Debris must be cleared with priority given to the routes that must be opened to support health, shelter, and relief operation.
- The arrangement of the identified shelters with designated TSMC according to the plan for receiving people.
- Preparation of the designated emergency health facilities with designated EHFMC along with all the doctors and nurses to serve the injured people.
- The arrangement of inventory and equipment supply at Ward Co-ordination Center.

c) Activities from 72 Hours to 14 Days of an Earthquake Event

- Continue search and rescue operation
- Continue disaster victim registration
- Initiation of temporary shelter operation. The victims should be brought from the evacuation space and directly from the rescue spot to a temporary shelter. Necessary first aid should be provided to the injured people. The designated shelter management team should manage the shelter along with the help of the evacuees. Need for supplies and equipment should be estimated properly.

- Provide treatment to the injured people accordingly in the designated emergency health facilities.
- Collection of reliefs assigned to the community by the relief team from government agencies, NGOs, international organizations etc. From the center, reliefs should be distributed to the temporary shelters and the emergency health facilities according to the requirement. In the center, there should be food preparation facility. Here food for the victims should be prepared, where food preparation standards should be observed. The prepared food should be disseminated in nearby shelters and health facilities as required.
- Establishment of necessary extra emergency setups
- It will not be possible to construct permanent houses immediately. Therefore, initiatives to construct transition shelters should be taken.

d) Activities from 14 Days to 60 Days of an Earthquake Event

- Full shelter capability should be maintained.
- The facilities of emergency health facilities should be continued.
- Relief management should be continued
- Construction of transition shelter should be initiated and completed
- Transfer of victims from temporary shelter to transition shelters or the repaired residential houses should be initiated.

e) Activities from 60 Days to One Year of an Earthquake Event

- The transfer of victims from temporary shelter to transition shelters or the repaired residential houses should be completed.
- The temporary shelters should be closed and the regular activities should be started.
- The construction work of permanent shelters should be started. The shelters should be allocated on land where the beneficiaries lived before the earthquake, promoting the return of displaced people to their places of origin.
- The transition of families to permanent housing should be initiated.
- Mental trauma and distress should be addressed by providing psycho-social and mental health services with the help of specialists.
- Progress reports must be sent to the Municipal Committee

- Children under 16 years of age not accompanied by one of their own parents are to be registered separately.
- Required information: Names and ages of all family members, any health problems and pre-disaster address
- When initially registered, each person is to be issued with an identification tag.
- Keep link with relief team to inform the team about the foods required for the occupants.

8.2 Institutional Arrangements for Temporary Shelter

Management

Management of temporary shelter and health facilities are extremely important for risk reduction as well as an effective management after an earthquake. Temporary shelters provide habitation and protection for the affected people and in the meantime, outcomes of the disaster can be evaluated and rectified. In this study, open space, playground, religious and educational buildings and spaces in public building used for community facilities were considered as temporary shelters. Therefore, a structured and organized committee will be needed to run these shelters smoothly. This committee will be addressed as Temporary Shelter Management Committee (TSMC). Figure 8.2 shows the structure of Temporary Shelter Management Committee (TSMC) and their activity at different phases of earthquake management. TSMC is responsible to conduct different tasks like food preparation, primary medical care etc. A team of total twelve members headed by a manager and one assistant manager needs to be constituted for one TSMC. Therefore, total number of members will depend on the severity of earthquake as number of temporary shelters after an earthquake will be defined by the severity and damage of an earthquake. It is evident from questionnaire survey that 17% (28 out of 166) of the respondents are willing to be involved in the disaster management activities in their wards (Chapter 6). Therefore, these people will have to be contacted and encouraged to be involved in the management committee.

The manager and assistant manager of this committee would act as leaders to manage the temporary shelter. They would not only co-ordinate tasks among the members of the team but would regularly maintain contact with Ward Co-ordination Center in the aftermath of the earthquake. The manager of TSMC would preferably be a member of

Ward Disaster Management Committee (WDMC) (Figure 7.2). All other members of the committee must be residents of the ward. The members should be educated and well informed about the vulnerability of the area. Each member should be familiar with the building or space to be used as temporary shelter: its size, facilities, and day-to-day level of supplies.

For an educational institution, the principal and assistant principal or others designated by them may be the manager or assistant manager of the temporary shelter. The regular staff working in the building such as office and maintenance staff can also be involved in management committee, as they have the complete knowledge of the facility and can best safeguard against damage and misuse. If necessary, volunteers can be engaged to serve the purpose.

The members and others involved in the committee should be properly trained and their activities and responsibilities at different phases of disaster should be assigned. Regular monitoring and maintenance should be done. The assigned members should also keep contact with the Ward Co-ordination Center and other agencies and institutions if necessary. All the members of the team should meet at least once in two months to keep updated about the responsibilities.

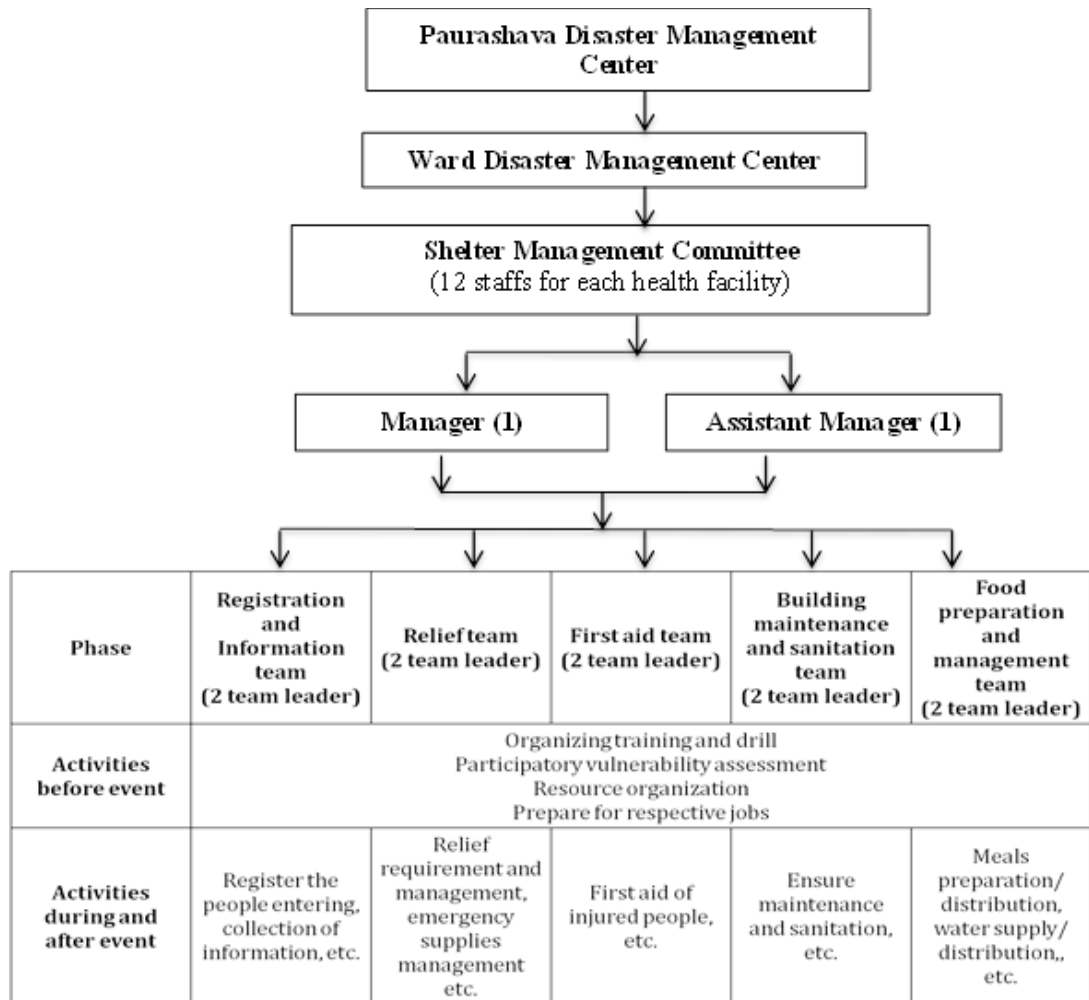

Source: Adapted from Barua, Tasneem, and Azad, (2014)

Figure 8.2: Structure of Temporary Shelter Management Committee (TSMC) and their activity at different phases of an earthquake

8.2.1 General Responsibilities of Teams in TSMC

8.2.1.1 Shelter Manager and Assistant Shelter Manager

The manager and assistant manager should be responsible for overall management and decision making about the temporary shelter. Assistant manager should assist the manager to carry on the activities. They should guide all the teams to carry on their activities. The activities of shelter manager and assistant manager are described below:

a) Pre-disaster

- Responsible for the temporary shelter before, during and after a disaster;

- Should be familiar with instructions and responsibilities.
- Keep link with the Temporary Shelter Management Team of WDMC.
- Maintain and update the list of all Shelter Managers and other personnel attached to the shelter with their contact list and keep copies of the list at the shelter.
- Participate in training and make sure about the participation of other staffs of the committee in training program.
- Responsible to form teams for Temporary Shelters Management Committee along with staffs.
- Ensure all personnel are available for duty at shelter and have been fully aware of management system
- Inspect the shelter regularly.

b) Response

- Contact leaders of Community Based Organizations (CBOs) and NGOs in order to arrange for assistance during disaster
- Allocate space for incoming evacuees.
- Move furniture as necessary.
- Keep a 24-hour log of shelter activities.
- Monitor registration, internal distribution, requisition system.
- Oversee maintenance and distribution of the emergency food and water supplies.
- Arrange for the installation of additional temporary facilities: showers and toilets.

c) Post-disaster

- Oversee the sanitation and hygiene of the temporary shelter.
- Establish an in-house health care programme, to be monitored and supervised by a first aid and medical care station within the shelter.
- Establish a social activity programme for evacuees, who due to the extent of the disaster, may be required to remain in the shelter for a longer period.
- Be in charge of requisition and distribution system for supplies.

- Maintain a system of record keeping facilitating returning the building to its original condition upon closing, and document any

8.2.1.2 Registration and Information Team

The team should be responsible for keeping a simple record of every person who is housed in his shelter. All the people coming to the shelter should proceed to the registration desk before going on to their lodging area. It is important that people be registered as soon as they arrive in the shelter, or as soon as practicable.

a) Purpose of registration

- Keep records of all occupants.
- Ascertain useful skills and interests.
- Make work assignments to the occupants.
- Determine sleeping arrangements.
- Determine special requirements.
- Identify persons needing special care.
- Keep the shelter occupants informed of changes in the situation. This will help prevent rumors that could adversely affect morale and shelter occupants.
- Keep link with relief team to inform the team about the supplies required for the occupants.
- Keep link with the first aid team to inform the team about the medical services required for the occupants.

b) Registration Procedures

- All injured and homeless aging 16 years and over are to be registered separately on the approved form.
- Accompanied children less than 16 years of age are to be registered with their parent(s).
- Children under 16 years of age not accompanied by one of their own parents are to be registered separately.
- Required information: Names and ages of all family members, any health problems and pre-disaster address

- When initially registered, each person is to be issued with an identification tag.

8.2.1.3 Building Maintenance and Sanitation Team

The team should be responsible for the management of the cleanliness of the temporary shelter. The occupants can be involved in the assistance of the team. The team should be responsible for:

- Building maintenance
- Supervision of the sanitation of the shelter
- Waste disposal
- Safety and cleaning activity.
- Prepare and supervise the use of the grounds and yard for parking and recreation, if necessary
- Making the occupants aware about personal and community hygiene to prevent disease.

8.2.1.4 Food Preparation and Management Team

In general, preparation of food for a shelter operation falls into one of two categories:

(1) Preparing food within the shelter, where cafeteria facilities already exist, and (2) preparing food in Ward Co-ordination Center and disseminating in different shelters under its jurisdiction according to requirement. The occupants can be involved in the assistance of the team. The team should be responsible to:

- Prepare and distribute meals
- Develop simple basic menu in terms of foods available
- Set meal time
- Cleanup meals area
- Keep link with relief team to inform the team about the foods required for the occupants.

8.2.2 Phases for Temporary Shelter Management

The operations and management of a Disaster Shelter will be undertaken in a number of phases. These can be identified as: a) Pre-Activation of Temporary Shelters, b) Opening of Temporary Shelters, and c) Closure and Post-Activation of Temporary Shelters

8.2.2.1 Pre-Activation of Temporary Shelters

This is the preparedness period when no hazard is threatening or has impacted. The building is inspected and the committee team members are identified and oriented to their duties.

a) Meeting of shelter management team

- Organize monthly meeting of the TSMC
- Disseminate necessary updates
- Inform members of when and where to report
- Assign duties and delegate responsibilities

b) Inspection of buildings

- The shelter manager and members of the shelter management team must inspect the buildings regularly.
- Check building to ensure that essential facilities are in good working condition (running water, functioning toilets, power, kitchen, equipment)
- Check for any visible defects (loose connections, bolts and fasteners, roof, leaks, windows and doors).

c) Obtain Keys

- Shelter manager must have keys.
- Duplicate keys should be obtained and kept at an alternative location.
- Ensure that keys are kept securely along with proper labeling.

d) Maintain Communication

- Maintain link with WDMC.

- Assist with public information activities.
- Identify means of communication with community.

8.2.2.2 Opening Pre-Activation of Temporary Shelters

This represents the phase when a warning has been raised or an impact has occurred. The shelter is prepared for and accepts persons threatened or displaced by the impact of a hazard.

a) Pre-Occupancy

- Assess or assist the assessment team to assess the building immediately after an earthquake.
- Open shelter at designated time.
- Prepare shelter to receive evacuees along with marking designated areas.
- Check building to determine condition of facilities.

b) Occupancy

- Start pre-determined activities of the staffs: registration, information, relief management, sanitation, cook etc.
- Review duties, rules, areas and staff introduction to the occupants.
- Occupants should be made aware about personal hygiene and cleanliness along with the shelter cleanliness.
- Women and children should be assigned separate spaces to prevent gender-based violence
- Conduct daily meetings with shelter occupants and ensure proper security.
- Use identification badges for occupants and staffs.
- Assign tasks of occupants to support the team.
- Identify and select persons to organize and co-ordinate recreation activities from the occupants.
- Identify and select persons to coordinate religious activities from the occupants.

8.2.2.3 Closure and Post-Activation Pre-Activation of Temporary Shelters

This phase represents the period when occupation of the shelter is no longer necessary. At this stage, the shelter is cleaned, repaired, and returned to normal use. The activities include:

- Organize cleanup activity of buildings.
- Restore arrangement of building.
- Close up building and return keys.

8.3 Institutional Arrangements for Emergency Health Facility

Emergency health services are formal health services (hospital, clinic etc.) to treat the moderate and severely injured people after an earthquake (CDMP, 2009). The more the capacity of these facilities, the less risk people will face after a disaster. Therefore, it is important to perform its operation effectively and Emergency Health Facility Management Committee (EHFMC) is proposed to handle corresponding steps. Figure 8.4 shows the structure of Emergency Health Facility Management Committee (EHFMC) and their activity at different phases of earthquake management. A team of total twelve members headed by a manager and one assistant manager needs to be constituted to form one EHFMC. However, the health facilities of the study area already have management committee of their own. Therefore, to avoid conflict, the management of the existing facilities should be incorporated in the EHFMC. The manager and assistant manager of this committee would act as leaders to manage the emergency health facility. They would not only co-ordinate tasks among the members of the team but would regularly maintain contact with Ward Co-ordination Center in the aftermath of the earthquake. The manager of EHFMC would preferably be a member of Ward Disaster Management Committee (WDMC). All the members of the team should regularly meet (at least once in two months) to keep updated about the responsibilities.

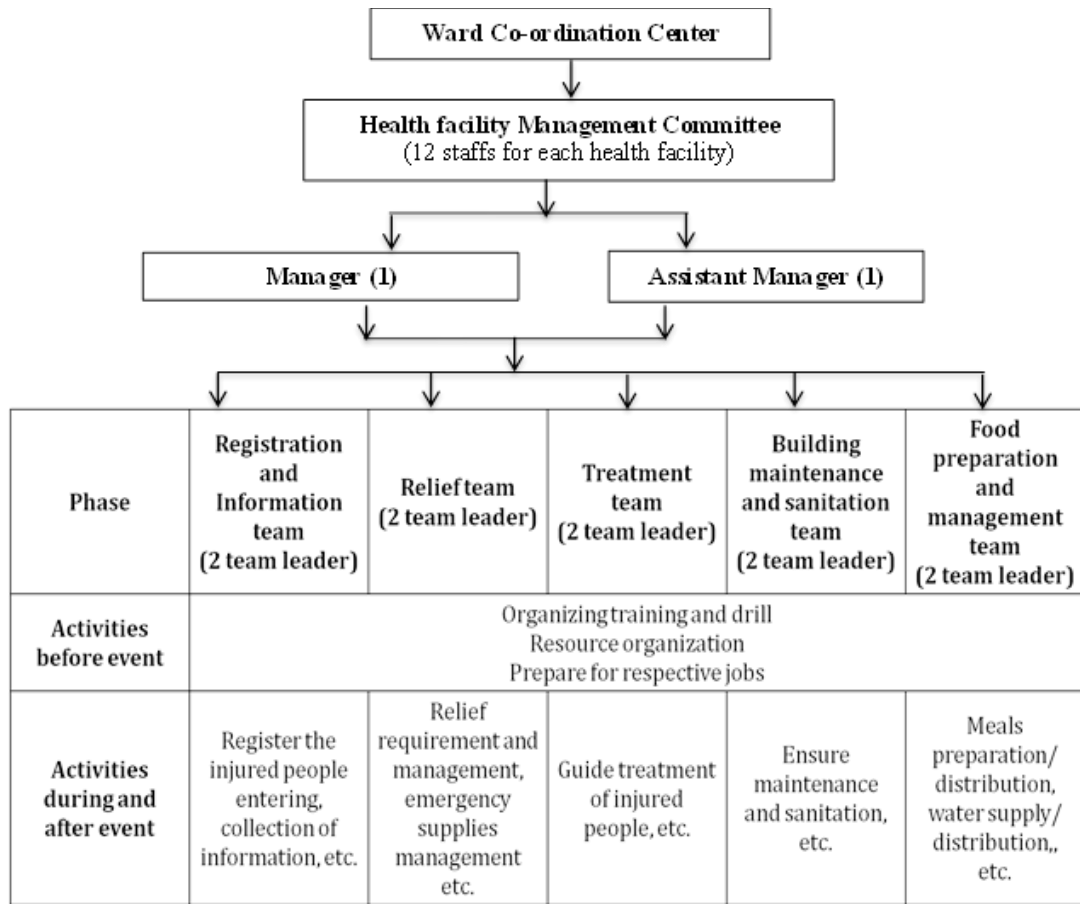

Source: Adapted from Barua, Tasneem, and Azad, (2014)

Figure 8.3: Structure of Emergency Health Facility Management Committee (EHFMC) and their activity at different phases of an earthquake

8.4 Activities of Relief Team

The team should ensure that the temporary shelter is supplied with required materials.

Responsibilities of the team are:

- Contact Relief Team of WDMC.
- Ensure availability of supplies needed
- Make necessary arrangements for receiving supplies
- Arrange for receipts of supplies
- Organize and secure proper storage of supplies
- Check and record supplies
- Maintain a daily count of people fed within shelter and report this information to Relief Team of WDMC.

8.5 Activities of First Aid Team and Rescue Team

The first aid team is team should comprise of persons who have been certified in First Aid by approved agency. And the rescue team could be formulated with local volunteers as mentioned at Chapter 6. They will work collaboratively with other teams after disaster. The major activities of the rescue team will be assisting Fire Service and Civil Defense group and taking the rescued persons in temporary shelter. They will also help to reach the rescued dead body in the designated place of the Ward.

If there are persons among the evacuees with training in the medical field, they should be identified and asked to assist the team. First aid team should be responsible for providing adequate medical and nursing services in all the shelters to care for the sick and injured, protect the health of residents, and provide mental support to the occupants. The team should keep link with relief team to inform the team about the instruments and medicines required for the treatment of occupants.

8.6 Institutional Setup of Ward Disaster Response Coordination Group and Center

As it has been mentioned before, tasks performed by different government agencies, private organizations, volunteers, and individuals are needed to be coordinated to get the maximum benefit. In addition, WDMC and Ward Disaster Response Coordination Group need a place to coordinate their works. For this co-ordination, a Ward Co-ordination Center is proposed in the study area. The composition of the Ward Disaster Response Coordination Group has been defined in the SOD 2019 (Appendix B). The BUET team has suggested the formation of further sub-committees under the Group. Figure 7.1 shows the structure of the Ward Disaster Response Coordination Group. Each team should contain two team leaders, but to manage the process properly each team will require subsequent team members. The members must meet prior to and during the onset of disaster. All the members of the committee should meet once in two months to keep update about the responsibilities and should keep a link with the WDMC, TSMC, and EHFMC.

The committee consists of the following teams.

- a) Temporary Shelter Coordination Team: Co-ordinate with all the TSMC.

- b) Health Facility Coordination Team: Co-ordinate with all the EHFMC.
- c) Rescue team: To take part in the rescue operation
- d) Relief team: To collect, manage and distribute reliefs in temporary shelters and emergency health facilities

8.6.1 General Criteria for Selecting Members of the Sub-Committees

All the members of the sub-committees should be residents of the area and familiar with the area. The committees must also keep a compulsory minimum number of females to better ensure supervision of gender-sensitive issues. It is also desirable that at least one member of the owners of the private medical facilities should be co-opted in the health facility management team under the Ward Disaster Response Coordination Group. The BUET team suggests there should be at least three members from the private medical facilities representing hospitals, clinics, and diagnostic centers accordingly. In addition, atleast one of them must be a female. The members and others involved in the committee should be properly trained and their activities and responsibilities at different phases of disaster will be assigned. The assigned members should keep contact with TSMC and EHFMC, other agencies and institutions.

CHAPTER 9 : CONCLUSION

It should be bear in mind that contingency plan is neither a stand-alone document nor a static document. It should be an ongoing process integrated and coordinated with activities suggested by other documents. It is well understood that earthquake would cause damaged at regional scale. Therefore, contingency plan at regional scale should be prepared. However, the issue, which bears the highest importance, is to count the effect of an earthquake on spatial dimension at local level. In the previous works on earthquake contingency plan in Bangladesh more importance was given on institutional activities and less focus on local level panning. In this project, involvement of local level planning and community participation was ensured in every level. The work on this ward is not completed yet and this involvement of local level planning and community participation will be ensured in the next stages. However, for successful implementation of the contingency plan, this kind of plan is needed to be prepared for the other wards of Sunamganj Pourashava.

REFERENCES

- ADPC. (n.d.). ADPC. Retrieved 28 May, 2017, from http://www.adpc.net: http://www.adpc.net/casita/Course%20Modules/Earthquake%20vulnerability%20reduction%20for%20cities/EVRC0302A_Social_cultural_and_economic_Vulnerability.pdfAkhter, S. H. (2010). Earthquakes of Dhaka. Asiatic Society of Bangladesh, p. 401-426.
- Argyroudis, S., Pitilakis, K., & Anastasiadis, A. (2005, May 23-25). Roadway Network Seismic Risk Analysis in Urban Areas: The case of Thessaloniki Greece. *Proc. International Symposium of GEOLINE, Lyon*. Retrieved 28 May, 2017 from: <http://www.geotechfr.org/sites/default/files/congres/geoline/GEOLINE2005%20S13%20pp%201-9%20Argyroudis.pdf>
- Alam, M., Ansary, M. A., Chowdhury, R. K., Uddin, A. J., Islam, S., & Rahman, S. (2008). Evaluation of Building's Vulnerability to Earthquake in Old Part of Sylhet and Construction Safety Rules. *IUST International Journal of Engineering Science, 19*(3).
- Bangladesh Bureau of Statistics. (2019). Bangladesh Statistical Year Book 2018. Retrieved 8th April, 2020 from: http://bbs.portal.gov.bd/sites/default/files/files/bbs.portal.gov.bd/page/b2db8758_8497_412c_a9ec_6bb299f8b3ab/SYB-2018.pdfCDMP. (2009). Earthquake Contingency Plan for Dhaka City. Dhaka: Comprehensive Disaster Management Programme (CDMP), Ministry of Food and Disaster Management, Government of the People's Republic of Bangladesh, Phase 1
- Brouwer, R., Akter, S., Brander, L., & Haque, E. (2007). Socioeconomic vulnerability and adaptation to environmental risk: a case study of climate change and flooding in Bangladesh. *Risk analysis, 27*(2), 313-326.CDMP. (2014). Scenario Based Earthquake Contingency Plan of Mymensingh Pourashava Area. Comprehensive Disaster Management Programme (CDMP), Ministry of Food and Disaster Management, Government of the People's

- Republic of Bangladesh. Retrieved 28 May, 2017, from <https://www.scribd.com/document/261613689/Earthquake-Contingency-Plan-of-Mymensingh-Pourashava-Area#>
- CDMP. (2009). Earthquake Contingency Plan for Dhaka City. Dhaka: Comprehensive Disaster Management Programme (CDMP), Ministry of Food and Disaster Management, Government of the People's Republic of Bangladesh, Phase 1
- CHTDF. (2010). *Earthquake Risk Reduction and Recovery Preparedness Programme in Chittagong Hill Tracts Area*, Ministry of Food and Disaster Management, Government of the People's Republic of Bangladesh
- Elahi, T. E., Islam, M. A. and Islam, M. S. (2018, December). *Stability Analysis of Selected Hill Slopes of Rangamati*. 4th International Conference on Advances in Civil Engineering 2018 (ICACE 2018).
- GoB. (2019). Standing Orders on Disaster. Dhaka: Ministry of Food and Disaster Management, Disaster Management & Relief Division, Disaster Management Bureau, Government of Bangladesh.
- HBRI. (2015). BNBC (Bangladesh National Building Code-Draft). (2015). Retrieved 18 November, 2019, from [www.scribd.com: https://www.scribd.com/document/ 363364110/33951114-BNBC-2015-pdf](https://www.scribd.com/document/363364110/33951114-BNBC-2015-pdf)
- Kumar, R., Bhargava, K., & Choudhury, D. (2016). Estimation of Engineering Properties of Soils from Field SPT Using Random Number Generation. *INAE Letters*, 1(3), 77-84.
- Lal, P., Alavalapati, J. R., & Mercer, E. D. (2011). Socio-economic impacts of climate change on rural United States. *Mitigation and Adaptation Strategies for Global Change*, 16(7), 819. Retrieved 28 May, 2017, from [http://ecoadapt.org/data documents/NPCWHumanDimensionsResources.pdf](http://ecoadapt.org/data/documents/NPCWHumanDimensionsResources.pdf)
- Mnestudies.com. (2018). Types of Vulnerabilities - Physical, Social, Economic, Attitudinal Vulnerability Monitoring and Evaluation Studies. Retrieved 28 May, 2017, from <http://www.mnestudies.com/disaster-management/vulnerability-types> NORSAR (Norwegian Seismic Array). (2018).

Structural Vulnerability Assessment. Retrieved 28 May, 2017, from <https://www.norsar.no/r-d/safe-society/earthquake-hazard-risk/structural-vulnerability-assessment/>

Ministry of Disaster Management and Relief. (2015). *National Debris Management Guidelines*. Bangladesh: Author.

MoDMR. (2015). *Atlas seismic risk assessment in Bangladesh for Bogra, Dinajpur, Mymensingh, Rajshahi and Tangail*. Dhaka: Ministry of Disaster Management and Relief, GoB.

Rapid Visual Screening of Buildings for Potential Seismic Hazards: A Handbook, Third Edition, FEMA P-154, January 2015.

Xu, W., Okada, N., Hatayama, M., & He, C. (2006). Conceptual Model of Shelter Planning Based on the Vitae System. *Annuals of Disaster Prevention Research Institute (DPRI)*, Kyoto University, 49 (B), pp 181-189.

World Bank Institution. (2012). *The Great East Japan Earthquake: Learning from Megadisasters: Knowledge Notes*. The World Bank, Washington DC. Retrieved 28 May, 2019, from: <http://wbi.worldbank.org/wbi/megadisasters>

APPENDIX A

Project Information

Bangladesh hopes to transform from Least Developed Country (LDC) category to developing Country by 2024 through better health and education, lower vulnerability and an economic boom (UN, 2018). Disaster risk reduction remains a key priority of the Government of Bangladesh, which is reflected in its Five-Year Plans, Perspective Plan, Bangladesh Delta Plan, and various national policies. Bangladesh has also adopted global frameworks like SDGs, Sendai Framework etc. However, Bangladesh has to maintain a holistic approach and to mainstream disaster risk reduction into development planning based on achievements and lessons. Bangladesh government and United Nations Development Programme (UNDP), UN Women and United Nations Office for Project Services (UNOPS) have jointly initiated the National Resilience Programme (NRP) with the financial support of the Department for International Development (DFID) and the Swedish International Development Cooperation Agency (SIDA) to sustain the resilience of human and economic development in Bangladesh through an inclusive and gender responsive disaster management. The programme aims at to provide strategic support to improve national capacity to keep pace with the changing nature of disasters.

The programme consists of four sub-projects or parts. Each sub-project is implemented by one implementing partner from the Government. These implementing partners are: Department of Disaster Management (DDM) of the Ministry of Disaster Management and Relief, Department of Women Affairs of the Ministry of Women and Children Affairs, Programming Division of the Ministry of Planning, and Local Government Engineering Department of the Ministry of Local Government, Rural Development and Co-operatives.

In NRP, DDM part aims to work towards improving community resilience by creating replicable, cost-effective models around DRR inclusive social safety nets, pro-active response solutions, earthquake preparedness, search and rescue, community-based flood preparedness that have shown promise in earlier initiatives. The objectives of the Department of Disaster Management part are:

- To advocate for implementation of the Sendai framework and build necessary capacity to monitor the implementation.
- To strengthen disability-inclusive, gender-responsive national capacities to address recurrent and mega disasters (including training of key personnel).

- To strengthen disability-inclusive, gender-responsive community preparedness, response and recovery capacities for recurrent and mega disasters.

As earthquake is a sudden perilous natural disaster and it can cause large-scale damage, an inclusive earthquake risk management approach is required to minimize the loss.

APPENDIX B

Table: Composition the Divisional Disaster Management Committee

1	Divisional Commissioner	Chairperson
2	DIG, Bangladesh Police	Member
3	Representative, Armed Forces Division	Member
4	Divisional Officer, DG Health Service	Member
5	Divisional Officer, Agricultural Extension Department	Member
6	All Deputy Commissioner of the concerned Division	Member
7	Divisional Officer, Department of Fisheries	Member
8	Divisional Officer, Livestock Department	Member
9	Divisional Officer, Secondary and Higher Secondary Education Department	Member
10	Divisional Officer, Primary Education Department	Member
11	Divisional Officer, Department of Women's Affair	Member
12	Divisional Officer, Department of Food	Member
13	Divisional Officer, Department of Public Health Engineering	Member
14	Divisional Officer, Education Engineering Department	Member
15	Divisional Officer, Water Development Department	Member
16	Divisional Officer, Department of Public Works	Member
17	Divisional Officer, Roads and Highways Department	Member
18	Divisional Officer, Power Development Board	Member
19	Divisional Officer, Rural Electrification Board (where necessary)	Member
20	Divisional Officer, Department of Youth Development	Member
21	Divisional Officer, Department of Cooperatives	Member
22	Divisional Officer, Department of Social Services	Member
23	Divisional Officer, Bangladesh Ansar and VDP	Member
24	Divisional Officer, Department of Information	Member
25	Representative, Border Guard Bangladesh	Member
26	Representative, Rapid Action Battalion	Member
27	Divisional Officer, Bangladesh Fire Service and Civil Defence	Member
28	Representative, Bangladesh Small and Cottage Industries Corporation	Member
29	An officer of the State-owned Commercial Bank nominated by the Divisional Commissioner	Member
30	Representative, City Corporation	Member
31	Divisional Officer, Bangladesh Meteorological Department	Member
32	Representative, Bangladesh Red Crescent Society	Member
33	Representative, Disaster Preparedness Programme	Member
34	One Male and one Female of socially respectable or civil society member nominated by the Divisional Commissioner	Member
35	Three representatives from a Non-Governmental Organization (NGO) that have activities at local, national or international levels nominated by the Divisional Commissioner, where there will be a representative from an organization involved in disability-related work.	Member
36	President, Press Club at Divisional level	Member
37	President, Chamber of Commerce and Industries	Member
38	Divisional Officer, Bangladesh Betar	Member
39	Divisional Officer, Bangladesh Television	Member
40	Representative, Electronic Media	Member
41	Representative, Community Radio	Member
42	Representative, Bangladesh Road Transport Owners Association	Member
43	Representative, Bangladesh Road Transport Workers Federation	Member
44	Representative, Scouts and Rover Scouts	Member
45	Representatives of organizations that work with persons with disabilities	Member
46	Organizations (government/non-government) working on mental health and psycho-social issues	Member
47	Director, Local Government	Member-Secretary

Table: Composition the District Disaster Management Committee

1	Deputy Commissioner	Chairperson
2	Chief Executive Officer, Zilla Parishad	Member

3	Chief Executive Officer, City Corporation (where necessary)	Member
4	Super of Police	Member
5	Civil Surgeon	Member
6	Deputy Director, Local Government	Member
7	Deputy Director, Department of Agriculture Extension	Member
8	District Fisheries Officer	Member
9	District Livestock Officer	Member
10	District Education Officer	Member
11	District Primary Education Officer	Member
12	District Women Affairs Officer	Member
13	District Food Controller	Member
14	District Officer, Department of Environment	Member
15	Executive Engineer, Public Health Engineering Department	Member
16	Executive Engineer, Education Engineering Department	Member
17	Executive Engineer, Water Development Board	Member
18	Executive Engineer, Public Affairs Department	Member
19	Executive Engineer, Roads and Highways Department	Member
20	Executive Engineer, Local Government Engineering Department	Member
21	Executive Engineer, Power Development Board/Rural Electrification Board/Dhaka Electric Supply Company Limited/ Dhaka Power Distribution Company Limited/ West Zone Power Distribution Company Limited/Rural Power Association or other concerned electricity Distribution Authority (where necessary)	Member
22	Deputy-Director, Youth Development Department	Member
23	Deputy-Director, Bangladesh Rural Development Board	Member
24	Deputy-Director, Department of Social Services	Member
25	District Cooperative Officer	Member
26	District Commandant, Bangladesh Ansar and VDP	Member
27	District Information Officer	Member
28	Representative, Border Guard Bangladesh (border district)	Member
29	Representative, Armed Forces Division (where necessary)	Member
30	Representative, Rapid Action Battalion	Member
31	Assistant/Deputy Assistant Director, Bangladesh Fire Service and Civil Defence Department	Member
32	District Representative, Bangladesh Small and Cottage Industries Corporation	Member
33	An officer of the State-owned Commercial Bank nominated by the Deputy Commissioner	Member
34	All Upazila Parishad Chairperson of the concerned district	Member
35	Municipality Mayor of District Headquarters	Member
36	All UNO under the concerned district	Member
37	Representative, Bangladesh Meteorological Department	Member
38	District Representative, Bangladesh Red Crescent Society	Member
39	Representative, Disaster Preparedness Programme	Member
40	One Male and one Female of socially respectable or civilized society nominated by the Deputy Commissioner	Member
41	Five Representatives of Non-Governmental Organizations (NGOs) that have activities at the local level designated by the Deputy Commissioner, where there will be a representative of an organization associated with disability-related work.	Member
42	President, District Press Club	Member
43	President, District Lawyers Association	Member
44	President, District Chamber of Commerce Industries	Member
45	District President, Secondary Teachers Association	Member
46	District President, Primary Teachers Association	Member
47	A Principal of a college or madrasa nominated by the Deputy Commissioner	Member
48	District Representative of electronic media, community radio and Betar (one from each)	Member
49	Representative, Bangladesh Road Transport Owners Association	Member
50	Representative, Bangladesh Road Transport Workers Federation	Member
51	District Commander, Freedom Fighter District Command	Member
52	General Secretary, Scouts and Rover Scouts	Member
53	Representative of organizations that work with persons with disabilities	Member
54	Organizations (government/non-government) working on mental health and psycho-social Issues	Member
55	District Relief and Rehabilitation Officer	Member-Secretary

Table: Composition of the District Disaster Response Coordination Group

1	Deputy Commissioner	Chairperson
2	Superintendent of Police	Member
3	Civil Surgeon	Member
4	Executive Engineer, Bangladesh Water Development Board	Member
5	Executive Engineer, Power Development Board	Member
6	District Food Controller	Member
7	One representative nominated by the Armed Forces Division	Member
8	Mayor, concerned municipality	Member
9	Deputy Director, Department of Agricultural Extension	Member
10	District Education Officer	Member
11	District Primary Education Officer	Member
12	Representative, Cyclone Preparedness Programme (if available)	Member
13	Representative, Bangladesh Red Crescent Society	Member
14	One Representative from a local or national NGO, nominated by the Deputy Commissioner	Member
15	One District level officer of the Bangladesh Fire Service and Civil Defense	Member
16	District Relief and Rehabilitation Officer (DRRO)	Member-Secretary

Table: Composition of the City Corporation Disaster Management Committee

1	Mayor	Chairperson
2	Chairperson, RAJUK/ KDA/ CDA/ RDA	Member
3	President of the Chamber of Commerce and Industry at city level	Member
4	Respective Deputy Commissioner	Member
5	Police Commissioner of respective City Corporation	Member
6	All Ward Councilor	Member
7	Chief Engineer, City Corporation	Member
8	Chief Health Officer, City Corporation (if any)	Member
9	General Manager (Transportation), City Corporation	Member
10	Chief Town Planner (if any)	Member
11	Chief Sanitation Officer, City Corporation (if any)	Member
12	Representative, Public Works Department	Member
13	Representative, Road and Highways Department	Member
14	Representative, Directorate of Primary Education	Member
15	Representative, Directorate of Secondary and Higher Education	Member
16	Representative, Directorate of Technical Education	Member
17	Representative, Directorate of Madrasa Education	Member
18	Representative, Bangladesh Ansar and VDP	Member
19	Representative, Department of Geological Survey of Bangladesh	Member
20	Representative, Department of Bangladesh Fire Service and Civil Defence	Member
21	Representative, Bangladesh Telecommunications Company Limited (BTCL)	Member
22	Representative, Department of Disaster Management	Member
23	Representative, Directorate General of Health Services	Member
24	Representative, Gas (Titas/ Bakharabad/ Sylhet etc.) Transmission and Distribution Company Limited	Member
25	Representative, Bangladesh Power Development Board /DESA/ DESCO	Member
26	Representative of Civil Society (social/cultural personality, journalist, religious personality, nominated by the Chairperson of the committee), 5 persons	Member
27	Representative, Voluntary Blood Donation Organizations (Shandhani/ Badhan/ Quantum etc.)	Member
28	Women Representative (nominated by the Department of Women Affairs)	Member
29	Representative, from national and local level NGOs working in City Corporation Area, 3 persons (nominated by the Chairperson of the committee)	Member
30	Representative, BNCC	Member
31	Representative, Bangladesh Scouts	Member
32	Representative, Girls in Scouts	Member
33	Representative, WASA (if any)	Member
34	Representative, organization working for the development of persons with disabilities	Member
35	Representative, Anjuman Mufidul Islam	Member

36	Representative, Bangladesh Red Crescent Society	Member
37	Relief and Rehabilitation Officer of the respective district	Member
38	Representative, Department of Youth Development	Member
39	Representative, Press Information Department	Member
40	Representative, Bangladesh Inland Water Transport Authority (where applicable)	Member
41	Representative, Bangladesh Road Transport Authority	Member
42	Representative, BCIC	Member
43	Representative, Cyclone Preparedness Programme (CPP) (if any)	Member
44	Representative, Water Development Board	Member
45	Representative, Civil Aviation Authority of Bangladesh	Member
46	Representative, Bangladesh Railway	Member
47	Representative, Organization working on Mental Health and Psycho-social issues (government/NGO)	Member
48	Chief Executive Officer, City Corporation	Member-Secretary

Table: Composition of the City Corporation Disaster Response Group

1	Mayor	Chairperson
2	Representative nominated by the Divisional Commissioner (in terms of divisional city corporations) - 1	Member
3	Representatives nominated by the Chairman of Rajdhani Unnayan Kartipakkha, Khulna Development Authority, Chattogram Development Authority, Rajshahi Development Authority (as applicable) - 1	Member
4	Representative nominated by the Deputy Commissioner - 1	Member
5	Representative nominated by the Metropolitan Police Commissioner and Superintendent of Police (as applicable) - 1	Member
6	Representative nominated by the Armed Forces Division - 1	Member
7	Representative nominated by the concerned District Civil Surgeon - 1	Member
8	Chief Engineer, representative nominated by the Public Works Department	Member
9	Executive Engineer, representative nominated by the Department of Public-Health Engineering	Member
10	Executive Engineer, representative nominated by the Education Engineering Department	Member
11	One representative, nominated by the Director General of Bangladesh Fire Service and Civil Defence	Member
12	District Relief and Rehabilitation officer (DRRO) of the concerned district	Member
13	Representative, Bangladesh Red Crescent Society	Member
14	Chief Executive Officer, concerned city corporation	Member-Secretary

Table: Composition of the City Corporation Ward Disaster Management Committee

1	Ward Councilor	Chairperson
2	Female Councilor in reserved seat (one nominated by Mayor)	Vice-Chairperson
3	Four representatives, each from the government emergency services provider (gas, water, electricity and telephone) located at the ward level	Member
4	Representative from the Department of Health (nominated by the office of the District Civil Surgeon/Divisional Director)	Member
5	Representative of Ansar and VDP (nominated by the district/divisional office)	Member
6	One Imam and one Purohit or two leaders of any other religious groups nominated by the Ward Councilor	Member
7	Representative of registered social/cultural organization	Member
8	Representatives of teachers (school, madrasa and college) (nominated by district/divisional office), total 3	Member
9	Representative of Bangladesh Red Crescent Society (nominated by district/city unit)	Member
10	Representative of Fire Service and Civil Defence (nominated by district/city unit)	Member
11	Representative of local press club / local media person	Member
12	Representative of the organization, which deals with persons with disability	Member
13	Persons with disability at the local level	Member
14	Representative of freedom fighters (nominated councilor or local commander)	Member
15	Representative of women's organization nominated by the Councilor	Member
16	Ward social worker nominated by the district social service officer	Member
17	Representative of police (nominated from the local police station)	Member

18	Two trained urban volunteers nominated by the Councilor	Member
19	Local BNCC Representative	Member
20	Local SCOUTS Representative	Member
21	Representative of Anjuman Mufidul Islam	Member
22	Two local esteemed persons nominated by the Councilor	Member
23	Two representatives of NGOs (national and international NGOs)	Member
24	Representative of Post-Office (if available)	Member
25	Representative of the engineering department of the City Corporation	Member
26	Representative of immigrants (if available)	Member
27	Ward Secretary, City Corporation	Member-Secretary

Table: Composition of the City Corporation Ward Response Coordination Group

1	Councilor of the concerned ward	Chairperson
2	Elected female councilor of the concerned ward	Vice- Chairperson
3	One representative each from government emergency service agencies (gas, water, electricity and telephone) located in the ward	Member
4	Representative, Bangladesh Red Crescent Society (if available)	Member
5	Representative, Cyclone Preparedness Programme (if available)	Member
6	Two NGO representatives, nominated by the Group	Member
7	Two representatives from the religion community (imam/priest)	Member
8	Representative (disability organization) of people with special needs	Member
9	Two representatives from the local Scouts (leader or rover scouts or girls scouts)	Member
10	Media representative	Member
11	Representative of the local business community	Member
12	Two urban volunteers (1 male, 1 female)	Member
13	Representative, Bangladesh Fire Service and Civil Defence (if available)	Member
14	Representative of teachers from local educational institutions	Member
15	Secretary, City Corporation Ward (where necessary) or the representative nominated by the Ward Group	Member-Secretary

Table: Composition of the Municipal Disaster Management Committee

1	Mayor	Chairperson
2	Panel-Mayor	Vice-Chairperson
3	Councilor (All)	Member
4	Representative, District Administration	Member
5	Medical Officer or Sanitary Inspector, Municipality	Member
6	Executive Engineer/Assistant Engineer, Municipality	Member
7	Upazila Project Implementation Officer (PIO)	Member
8	Officer in Charge of the concerned Thana	Member
9	Representative, Bangladesh Red Crescent Society (if available)	Member
10	Station Officer, Upazila Fire Service and Civil Defence (if available)	Member
11	One Representative nominated by the Upazila Commander or Upazila Freedom Fighters Command Council	Member
12	Three representatives (nominated by the Mayor) from Non-Governmental Organizations (NGOs) that have activities at local, national and international levels where one member will have experience in gender and disability-related work.	Member
13	Representative of gas supply / distribution company (if the concerned area is under the gas transmission network)	Member
14	Representative, Power Development Board	Member
15	Representative, Agricultural Extension Department	Member
16	Representative, Executive Engineer, Public Health Engineering Department	Member
17	Representative of the President, District or Upazila Press Club (where applicable)	Member
18	Representative, Upazila Health and Family Planning Officer or Civil Surgeon (where necessary)	Member
19	One representative from civil society nominated by the Chairperson of the Municipal Committee	Member
20	Representative, Cyclone Preparedness Programme (if available)	Member

21	One Principal/Superintendent/Headmaster of college/madrasa/school nominated by the Chairperson of Municipal Committee	Member
22	Representative, Upazila Social Welfare Officer	Member
23	Representative, District or Upazila Chamber of Commerce/Local Business Leader (where applicable)	Member
24	Representative, Upazila or District Women Affairs Officer (where applicable)	Member
25	Representative, Executive Engineer, Rural Electrification Board, Rural Electrification Association or any other electricity distribution authority (where applicable)	Member
26	Representative, Bangladesh Water Development Board	Member
27	Representative, Upazila or District Ansar VDP officer (where applicable)	Member
28	Representative, Zilla or Upazila Parishad (where applicable)	Member
29	Representative, forum or association for persons with disabilities (if available)	Member
30	Representative, Deputy Director, Department of Family Planning	Member
31	Chief Executive Officer or Secretary of Municipality	Member-Secretary

Table: Composition of the Pourashava (Municipal) Disaster Response Coordination Group

1	Mayor	Chairperson
2	One representative nominated by Upazila Health and Family Planning Officer	Member
3	One representative nominated by Upazila Education Officer	Member
4	Project Implementation Officer (PIO)	Member
5	One representative nominated by the police station of the upazila	Member
6	One representative from Bangladesh Fire Service and Civil Defence	Member
7	One representative nominated by Public Health Engineering Department	Member
8	One representative from Bangladesh Red Crescent Society (if available)	Member
9	Representative, Cyclone Preparedness Programme (if available)	Member
10	One Representative from a local or national NGO working locally, nominated by the Mayor of the Pourashava	Member
11	Representative of volunteers organizations (Bangladesh Scouts, BNCC, BDRCS)	Member
12	Chief Executive Officer or Secretary	Member-Secretary

Table: Composition of the Municipal Ward Disaster Management Committee

1	Councilor of the concerned ward	Chairperson
2	Female Councilor of the concerned ward	Advisor
3	Teachers representative nominated by the committee	Member
4	Two Government officers/employees working at the ward level	Member
	Representative, Bangladesh Red Crescent Society (if available)	Member
6	NGO representative nominated by the committee (which has activities at the local level)	Member
7	Two religious representatives (Imam/Purohit)	Member
8	One representative from the population with special needs (representative of persons with disabilities)	Member
9	Representative of mass media (if available)	Member
10	Representative of the local business community	Member
11	Representative of tribal/indigenous community (if available)	Member
12	One representative nominated by the Ward Committee	Member-Secretary

Table: Composition of the Pourashava Ward Disaster Response Coordination Group

1	Councilor of the concerned ward	Chairperson
2	Elected Female Councilor of the concerned Ward	Member
3	One Representative each from government emergency service agencies (gas, water, electricity and telephone) located in the ward	Member
4	Representative, Bangladesh Red Crescent Society (if available)	Member
5	Representative, Cyclone Preparedness Programme (if available)	Member
6	Two NGO representatives, nominated by the group	Member
7	Two representatives from religion groups (Imam/priest)	Member

8	Representative (disability organization) of people with special needs	Member
9	Two representatives from local Scouts (leader or rover or girls scout)	Member
10	Media representative	Member
11	Representative of the local business community	Member
12	Two urban volunteers (1 male, 1 female)	Member
13	Representative, Bangladesh Fire Service and Civil Defence (if available)	Member
14	Representative of teachers from local educational institutions	Member
15	Representative nominated by the Ward Group	Member-Secretary

APPENDIX C

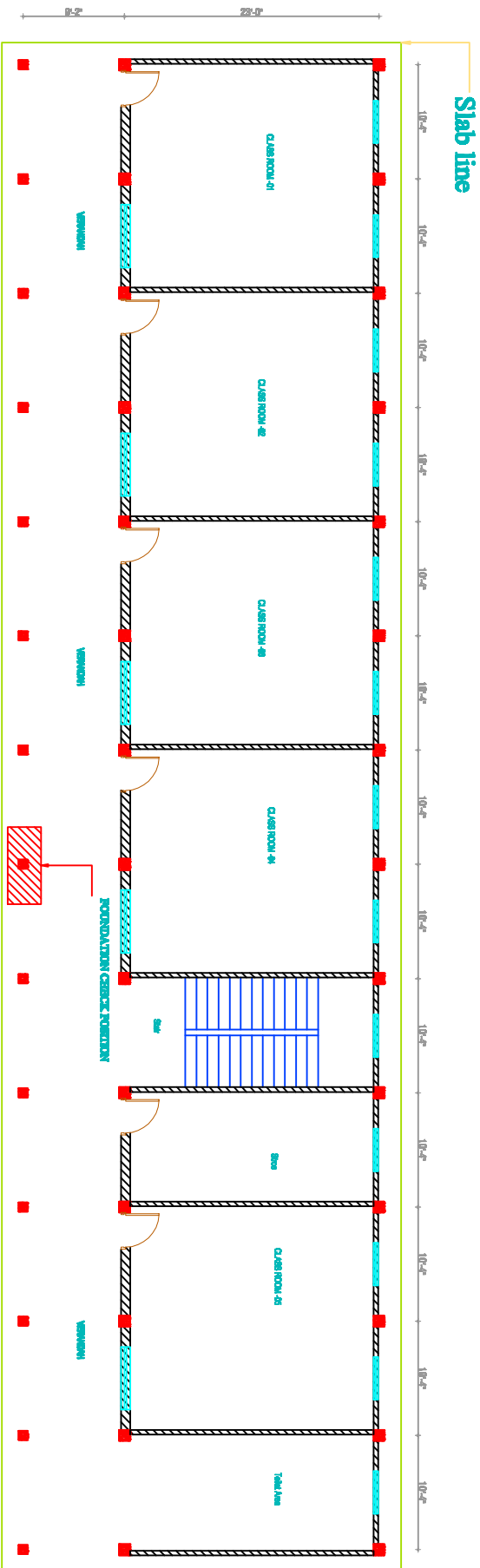

Floor Height: 10'-5"

- Legend**
- COLUMN
 - ▨ BRICK WALL



GR FLOOR TO 1ST FLOOR PLAN
Two Storied Rcc Building.

Project: Vulnerability Assessment of Earthquake Risk at Ward level, developing Contingency Plans, Proposing Training Modules and Imparting Training for Raigarh City Corporation and Tugadi, Raigarh and Bargarh/Jharsuguda.	Client:- National Resilience Program/central level	Consultant	Building Address: Govt S C Girls High School, Ward#4, Sunamganj.	Drawing Checked By: Shrantaonee Aziz Assistant Professor BUET-JIDPUS	CAD By: Esha AZIZAN RAHMAN Technical Officer, BUET-JIDPUS	Drawing Title GR FLOOR TO 1ST FLOOR PLAN	Page No. P-01	Scale Not to be scaled
							Date: SEP-2021	Job ID NA

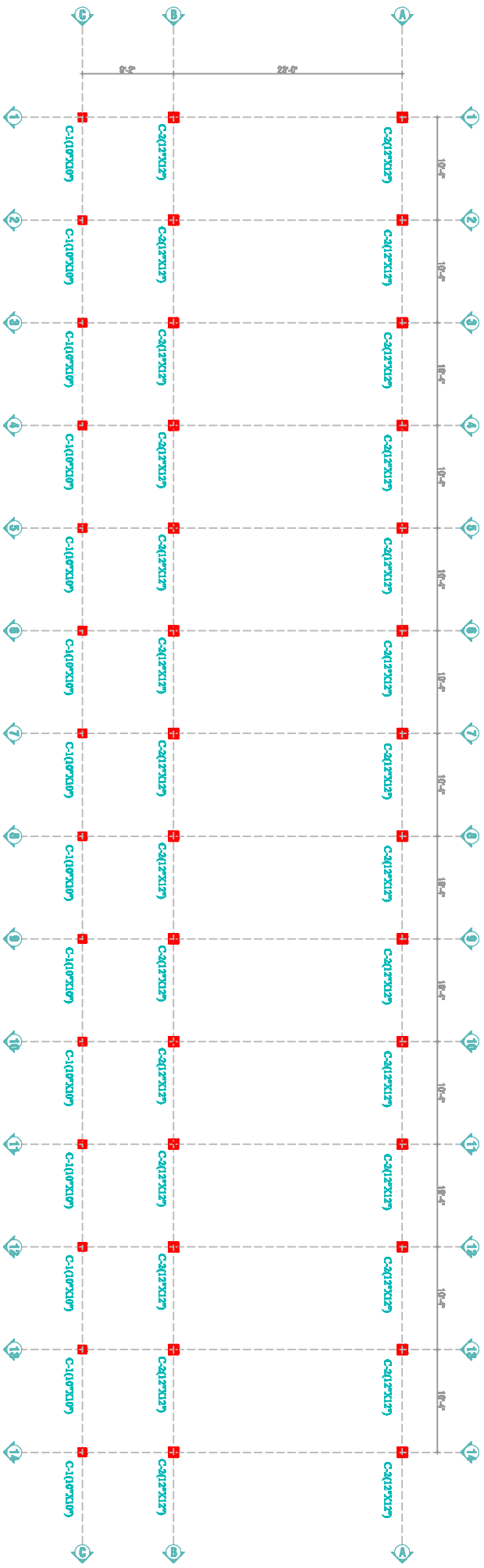

COLUMN LAYOUT (TYPICAL)
SCALE: NTS

Project: Vulnerability Assessment of Earthquake Risk at Ward level, developing Contingency Plans, Proposing Training Modules and Improving Training for Rajapur City Corporation and Tugayal, Rajapur and Sunamganj/Sunamganj.		Client: National Resilience Program/UNEP/ICR		Consultant: BUET-JIDPU INSTITUTE OF MASTER PREVENTION AND URBAN SAFETY, BUREAU OF RESEARCH TESTING AND CONSULTATION (B R T C), BANGLADESH UNIVERSITY OF ENGINEERING AND TECHNOLOGY (BUET) DHAKA-1000, BANGLADESH.		Building Address: Govt S C Girls High School, Ward#4, Sunamganj.		Drawing Checked By: Shamontee Aziz Assistant Professor BUET-JIDPUS		CAD By: Eben azuzen gannu Technical Officer, BUET-JIDPUS		Drawing Title: COLUMN LAYOUT		Page No.: P-02		Scale: Not to be scaled JOB ID NA	
														Date: SEP-2021			

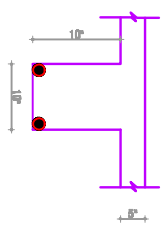

B-2 SECTION

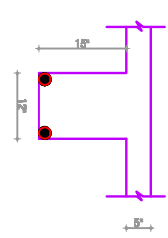

B-1 SECTION

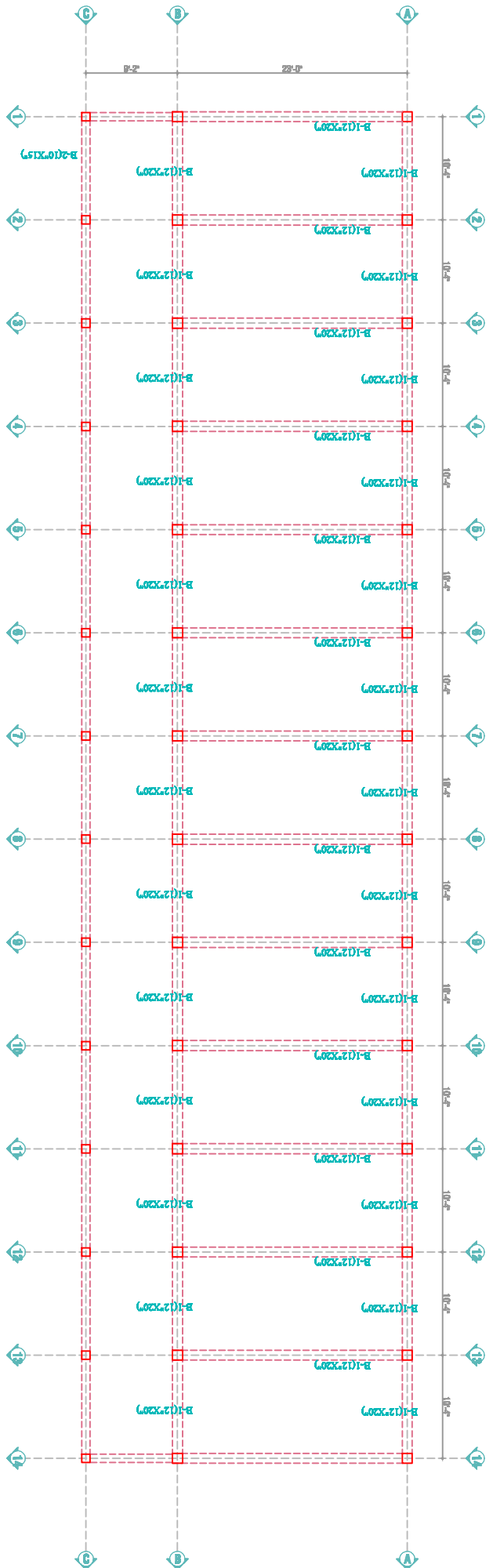

BEAM LAYOUT (TYPICAL)
SCALE: NTS

Project: Voluntary Assessment of Earthquake Risk at Ward level, developing Contingency Plans, Proposing Training Modules and Improving Training for Rajapur City Corporation and Tirupur, Bangalore and Guwahati/Sunamganj.		Client: National Resilience Program/Global Fund		Consultant: BUET-JIDPU INSTITUTE OF MASTER PREVENTION AND URBAN SAFETY, BUREAU OF RESEARCH TESTING AND CONSULTATION (B R T C), BANALAKSHI UNIVERSITY OF ENGINEERING AND TECHNOLOGY (BUET) DPOUC-100A, BANALAKSHI.		Building Address: Govt S C GHS High School, Ward#4, Sunamganj.		Drawing Checked By: Shamnoor Aziz Assistant Professor BUET-JIDPUS		CAD By: Eena Azween Samudra Technical Officer, BUET-JIDPUS		Drawing Title: BEAM LAYOUT		Page No.: P-03		Scale: Not to be scaled	
																Job ID: NA	
																Date: SEP-2021	



CONCRETE LABORATORY

BRTC No. : 1102-44550/ CE/ 21-22; Dt: 19/10/2021
 Client : BUET-Japan Institute of Disaster Prevention and Urban Safety, Dhaka-1000, BUET
 Ref. No. : BUET-JIDPUS/2021/37; Dt: 17/10/2021
 Project : Vulnerability Assessment of EQ Risk at Ward Level, Rangpur, Tangail, Rangamati, Sunamganj
 Sample : **Concrete Cylindrical Core** [Mix Proportion (as quoted): Not Mentioned]
 Year of Construction : Not Mentioned No. of Floors = Not Mentioned
 Sample Collected by : **Client**** Date of Sample Collection: _/ _/2021
 Test : **Compressive Strength of Concrete Cylindrical Core [ASTM C 42/C 42M]**
 Date of Test : 23/10/2021

TEST REPORT

Sl. No.	Location	Sample Identification Mark	Length of Sample	Diameter of Sample	Average Cross Sectional Area	Ultimate Load	Crushing Strength	Type of Failure
			in.	in.	sq. in.	lb.		
1	BCS-GF-C2/8	25	4.5	2.64	5.47	5,642	1010 psi (7 MPa)	Mortar (Stone Chips)
2	BCS-GF-B2	26	5.3	2.64	5.47	14,642	2670 psi (18.4 MPa)	Combined * (Brick Chips)
3	SCGS-GF-B/8	27	5.1	2.64	5.47	10,142	1850 psi (12.8 MPa)	Combined * (Stone Chips)

**Samples were received by BRTC in unsealed condition.

*Combined = Mortar and Aggregate failure

NOTE 1 — The diameter of core specimens for the determination of compressive strength in load bearing structural members shall be at least 3.70 in. [94 mm]. For non-load bearing structural members or when it is impossible to obtain cores with length-diameter ratio (L/D) greater than or equal to 1, core diameters less than 3.70 in. [94 mm] are not prohibited.

NOTE 2 — The compressive strengths of nominal 2-in. [50-mm] diameter cores are known to be somewhat lower and more variable than those of nominal 4-in. [100-mm] diameter cores. In addition, smaller diameter cores appear to be more sensitive to the effect of the length-diameter ratio.

COMMENT — Please compare the results with your corresponding design values and consult with your design engineer.

Countersigned by:

Dr. A. B. M. Badruzzaman
 Professor
 Department of Civil Engineering
 BUET, Dhaka-1000, Bangladesh

23



6A6SbA5Mg

Test Performed by

M. Mafizur Rahman
 23/10/21

Dr. Md. Mafizur Rahman
 Professor
 Department of Civil Engineering
 BUET, Dhaka-1000, Bangladesh



Warning: For samples supplied to us for testing in our laboratory, BRTC does not have any responsibility as to the representative character of the samples required to be tested. It is recommended that samples are sent in a secure and sealed cover/packet/container under signature of the competent authority. In order to avoid fraudulent fabrication of test results, it is recommended that all test reports are collected by duly authorized person, and not by the Contractor/Supplier.



CONCRETE LABORATORY

BRTC No. : 1102-44550/ CE/ 21-22; Dt: 19/10/2021
 Client : BUET-Japan Institute of Disaster Prevention and Urban Safety,Dhaka-1000,BUET
 Ref. No. : BUET-JIDPUS/2021/37; Dt: 17/10/2021
 Project : Vulnerability Assessment of EQ Risk at Ward Level,Rangpur,Tangail,Rangamati,Sunamganj
 Sample : **Concrete Cylindrical Core** [Mix Proportion (as quoted): Not Mentioned]
 Year of Construction : Not Mentioned No. of Floors = Not Mentioned
 Sample Collected by : **Client **** Date of Sample Collection: / /2021
 Test : **Compressive Strength of Concrete Cylindrical Core [ASTM C 42/C 42M]**
 Date of Test : 23/10/2021

TEST REPORT

Sl. No.	Location	Sample Identification Mark	Length of Sample	Diameter of Sample	Average Cross Sectional Area	Ultimate Load	Crushing Strength	Type of Failure
			in.	in.	sq. in.	lb.		
1	SCGS-1st-C10	28	2.8	2.64	5.47	11,042	1780 psi (12.3 MPa)	Combined * (Stone Chips)
2	APS-1st-S+B	29	4.7	2.64	5.47	18,468	3370 psi (23.2 MPa)	Combined * (Brick Chips)
3	GPS-GF-C1	30	4.7	2.64	5.47	6,317	1150 psi (7.9 MPa)	Combined * (Brick Chips)

**Samples were received by BRTC in unsealed condition.

* Combined = Mortar and Aggregate failure

NOTE 1 — The diameter of core specimens for the determination of compressive strength in load bearing structural members shall be at least 3.70 in. [94 mm]. For non-load bearing structural members or when it is impossible to obtain cores with length-diameter ratio (L/D) greater than or equal to 1, core diameters less than 3.70 in. [94 mm] are not prohibited.

NOTE 2 — The compressive strengths of nominal 2-in. [50-mm] diameter cores are known to be somewhat lower and more variable than those of nominal 4-in. [100-mm] diameter cores. In addition, smaller diameter cores appear to be more sensitive to the effect of the length-diameter ratio.

COMMENT — Please compare the results with your corresponding design values and consult with your design engineer.

Countersigned by:

Dr. A. B. M. Badruzzaman
Professor
Department of Civil Engineering
BUET, Dhaka-1000, Bangladesh

24



7Q2FGB8XG

Test Performed by

M. M. 23/10/21

Dr. Md. Mafizur Rahman
Professor
Department of Civil Engineering
BUET, Dhaka-1000, Bangladesh



Warning: For samples supplied to us for testing in our laboratory, BRTC does not have any responsibility as to the representative character of the samples required to be tested. It is recommended that samples are sent in a secure and sealed cover/packet/container under signature of the competent authority. In order to avoid fraudulent fabrication of test results, it is recommended that all test reports are collected by duly authorized person, and not by the Contractor/Supplier.



CONCRETE LABORATORY

BRTC No. : 1102-44550/ CE/ 21-22; Dt: 19/10/2021
 Client : BUET-Japan Institute of Disaster Prevention and Urban Safety, Dhaka-1000, BUET
 Ref. No. : BUET-JIDPUS/2021/37; Dt: 17/10/2021
 Project : Vulnerability Assessment of EQ Risk at Ward Level, Rangpur, Tangail, Rangamati, Sunamganj
 Sample : **Concrete Cylindrical Core** [Mix Proportion (as quoted): Not Mentioned]
 Year of Construction : Not Mentioned No. of Floors = Not Mentioned
 Sample Collected by : **Client **** Date of Sample Collection: / / 2021
 Test : **Compressive Strength of Concrete Cylindrical Core [ASTM C 42/C 42M]**
 Date of Test : 23/10/2021

TEST REPORT

Sl. No.	Location	Sample Identification Mark	Length of Sample	Diameter of Sample	Average Cross Sectional Area	Ultimate Load	Crushing Strength	Type of Failure
			in.	in.	sq. in.	lb.		
1	SCGS-GF-C8	31	5.2	2.64	5.47	12,167	2220 psi (15.3 MPa)	Combined * (Stone Chips)

**Samples were received by BRTC in unsealed condition.

* Combined = Mortar and Aggregate failure

NOTE 1 — The diameter of core specimens for the determination of compressive strength in load bearing structural members shall be at least 3.70 in. [94 mm]. For non-load bearing structural members or when it is impossible to obtain cores with length-diameter ratio (L/D) greater than or equal to 1, core diameters less than 3.70 in. [94 mm] are not prohibited.

NOTE 2 — The compressive strengths of nominal 2-in. [50-mm] diameter cores are known to be somewhat lower and more variable than those of nominal 4-in. [100-mm] diameter cores. In addition, smaller diameter cores appear to be more sensitive to the effect of the length-diameter ratio.

COMMENT — Please compare the results with your corresponding design values and consult with your design engineer.

Countersigned by:

Dr. A. B. M. Badruzzaman
Professor
Department of Civil Engineering
BUET, Dhaka-1000, Bangladesh



Test Performed by:

Dr. Md. Mafizur Rahman
Professor
Department of Civil Engineering
BUET, Dhaka-1000, Bangladesh



Warning: For samples supplied to us for testing in our laboratory, BRTC does not have any responsibility as to the representative character of the samples required to be tested. It is recommended that samples are sent in a secure and sealed cover/packet/container under signature of the competent authority. In order to avoid fraudulent fabrication of test results, it is recommended that all test reports are collected by duly authorized person, and not by the Contractor/Supplier.

Ferro-Scan Report
Ward No.: 04, Sunamganj Pourashava
Govt. S C Girls High School

Figure E-08 and Figure E-09 are showing the image scan of column GF-C1 (long side and short side respectively) at a height of 3'-10" from the floor surface. Figure E-10 is showing the cross section of that column.

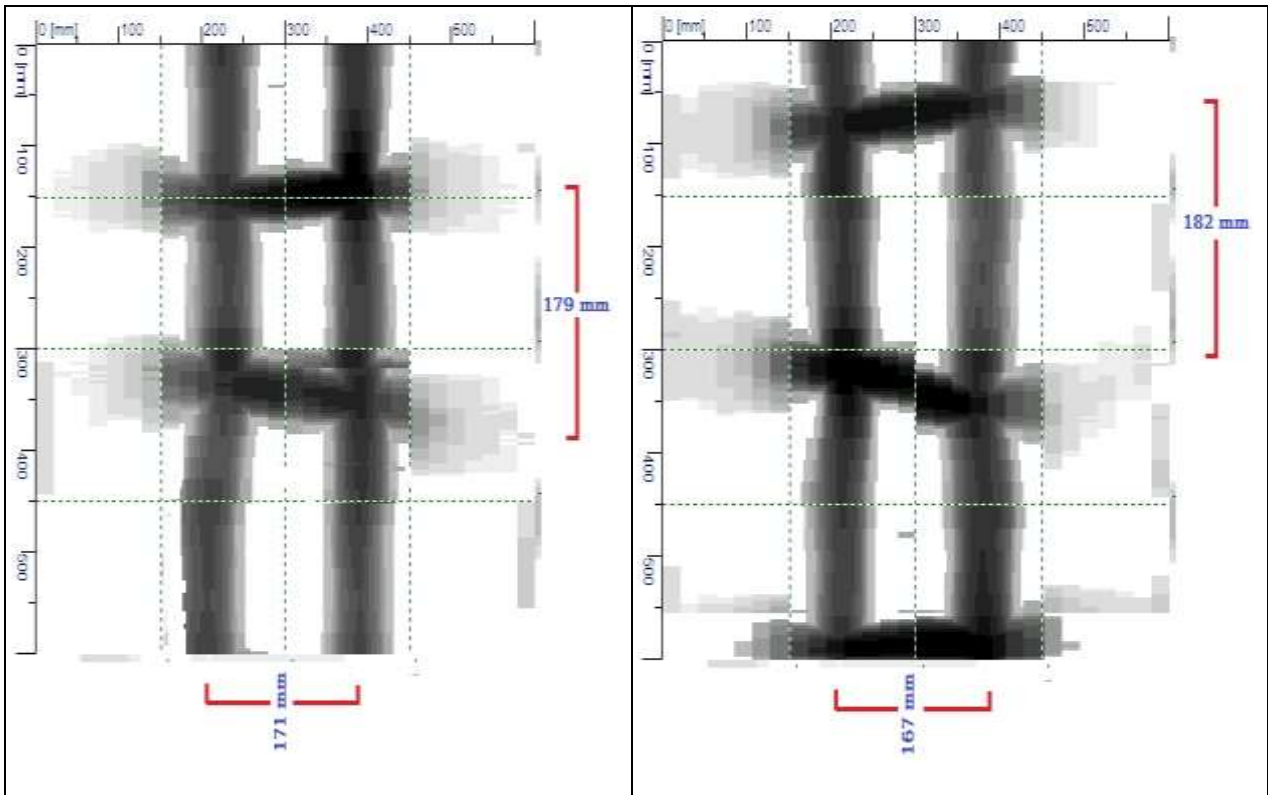

Figure E-08: Image scan of column GF-C1 (Long Side)

Figure E-09: Image scan of column GF-C1 (Short Side)

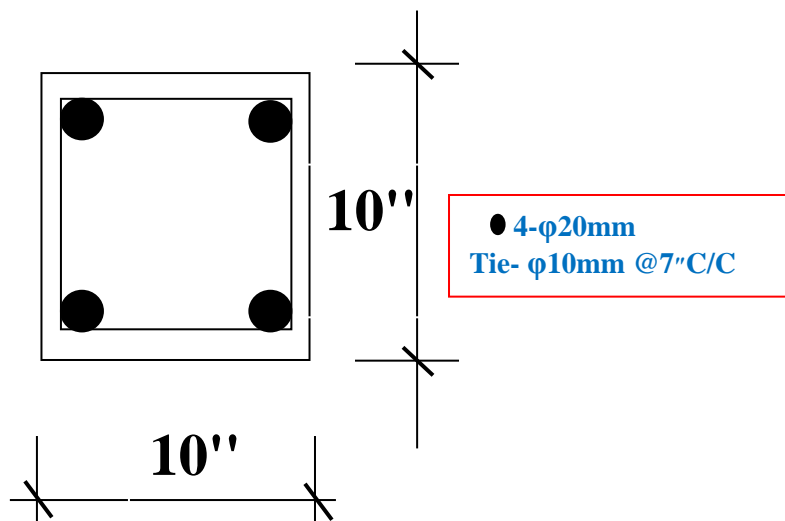

Figure E-10: Cross section of column GF-C1

Figure E-11 and Figure E-12 are showing the image scan of column GF-B2 (long side and short side respectively) at a height of 3'-10" from the floor surface. Figure E-13 is showing the cross section of that column.

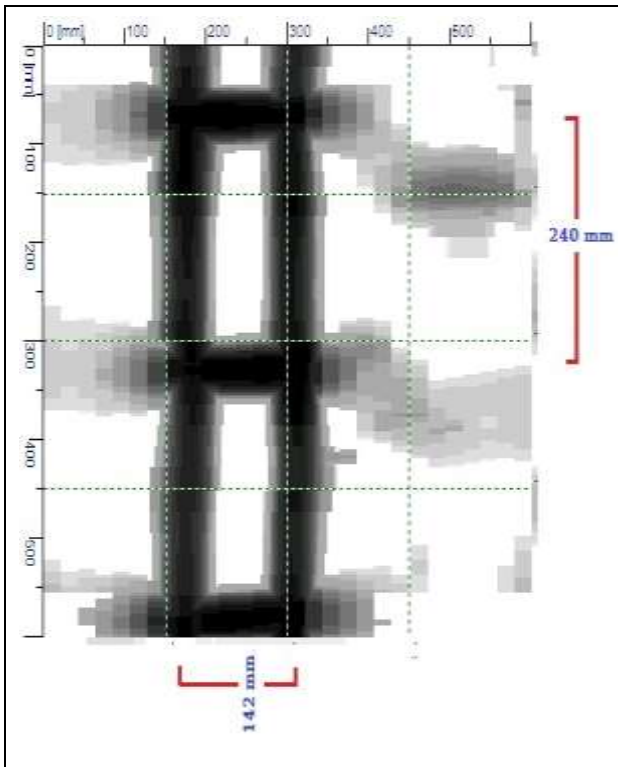

Figure E-11: Image scan of column GF-B2 (Long Side)

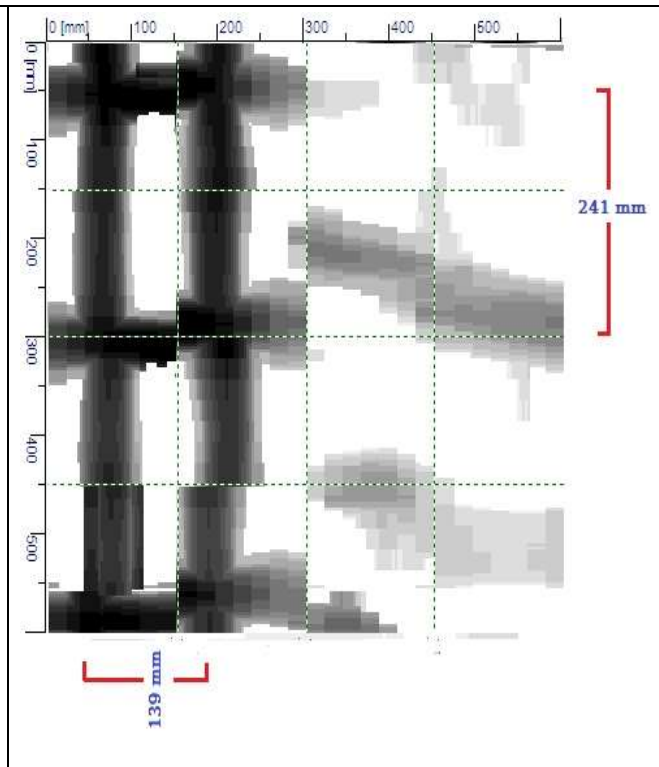

Figure E-12: Image scan of column GF-B2 (Short Side)

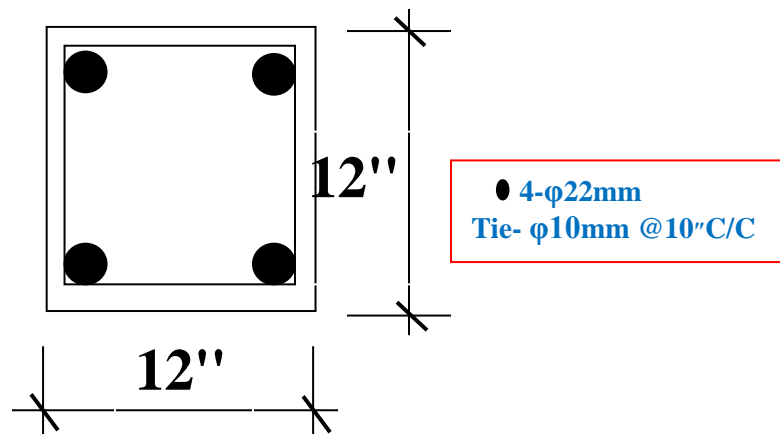

Figure E-13: Cross section of column GF-B2

Figure E-14 and Figure E-15 are showing the image scan of column 2F-B2 (long side and short side respectively) at a height of 3'-10" from the floor surface. Figure E-16 is showing the cross section of that column.

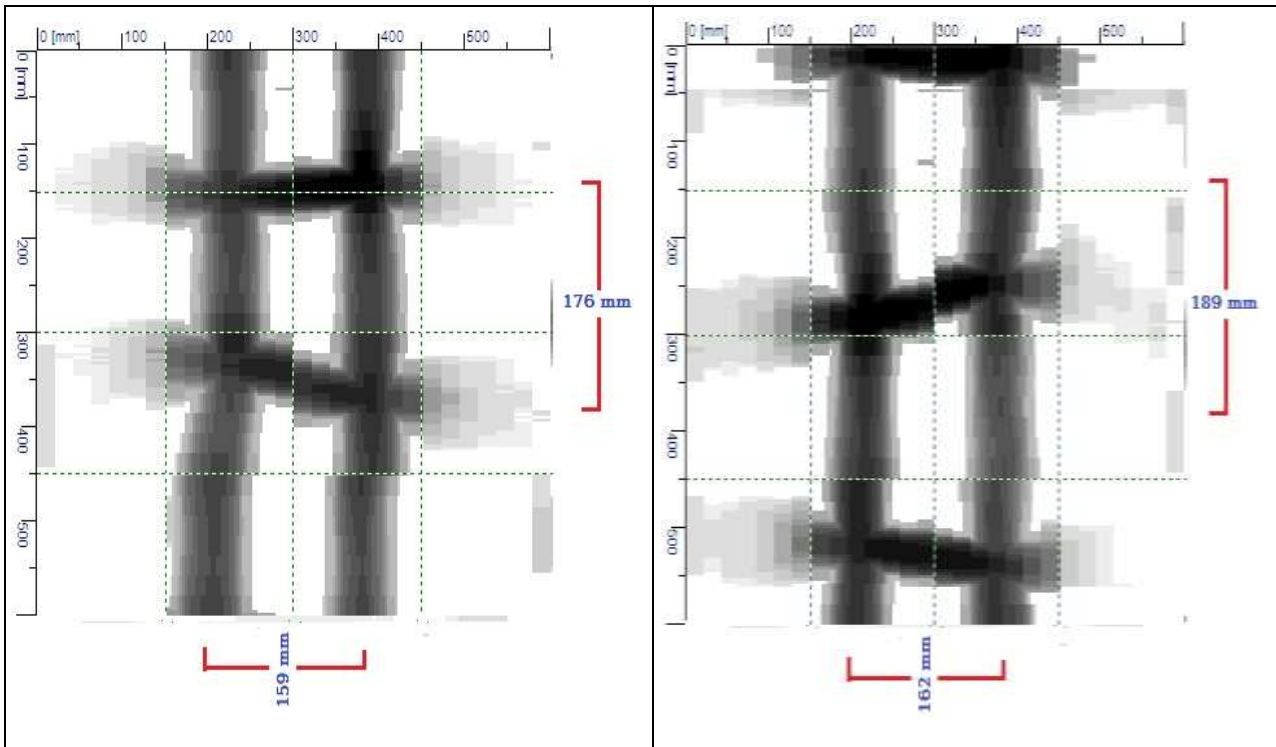

Figure E-14: Image scan of column 2F-B2 (Long Side)

Figure E-15: Image scan of column 2F-B2 (Short Side)

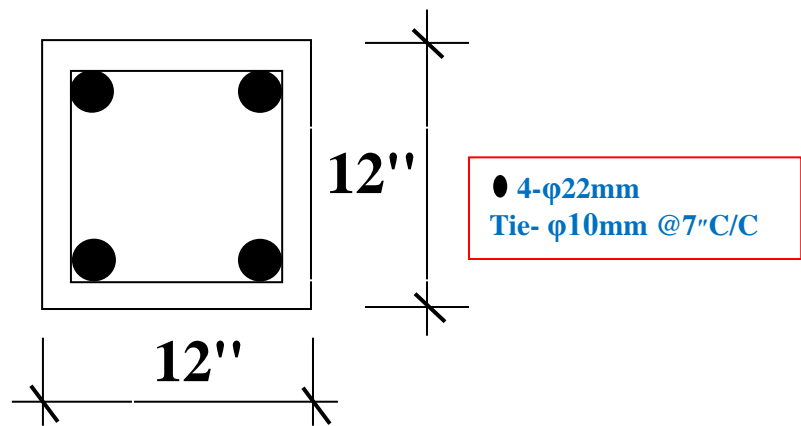

Figure E-16: Cross section of column 2F-B2

Figure E-17 and Figure E-18 are showing the image scan of beam 1F-B1 (lateral and bottom) at a height of 9'-10" from the floor surface. Figure E-19 is showing the cross section of that beam.

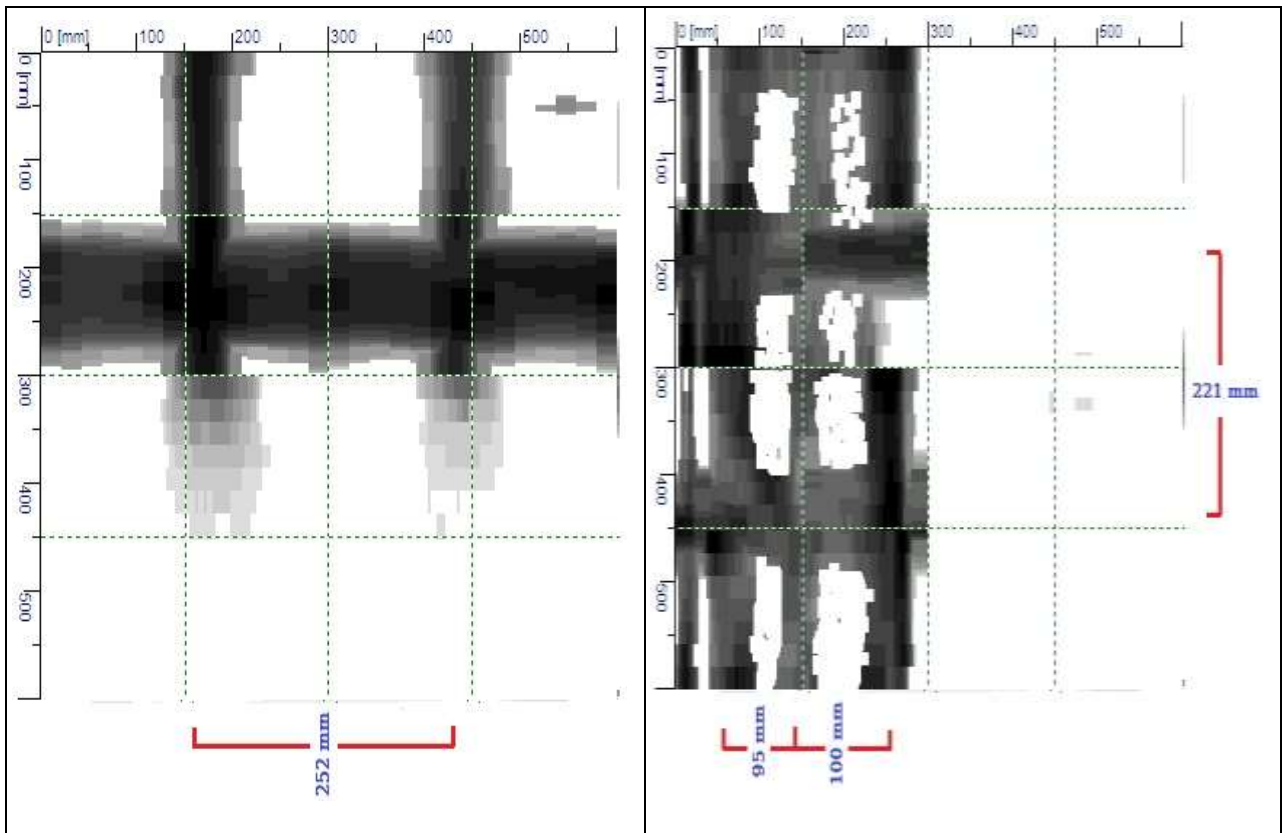

Figure E-17: Image scan of beam 1F-B1 (lateral)

Figure E-18: Image scan of beam 1F-B1 (bottom)

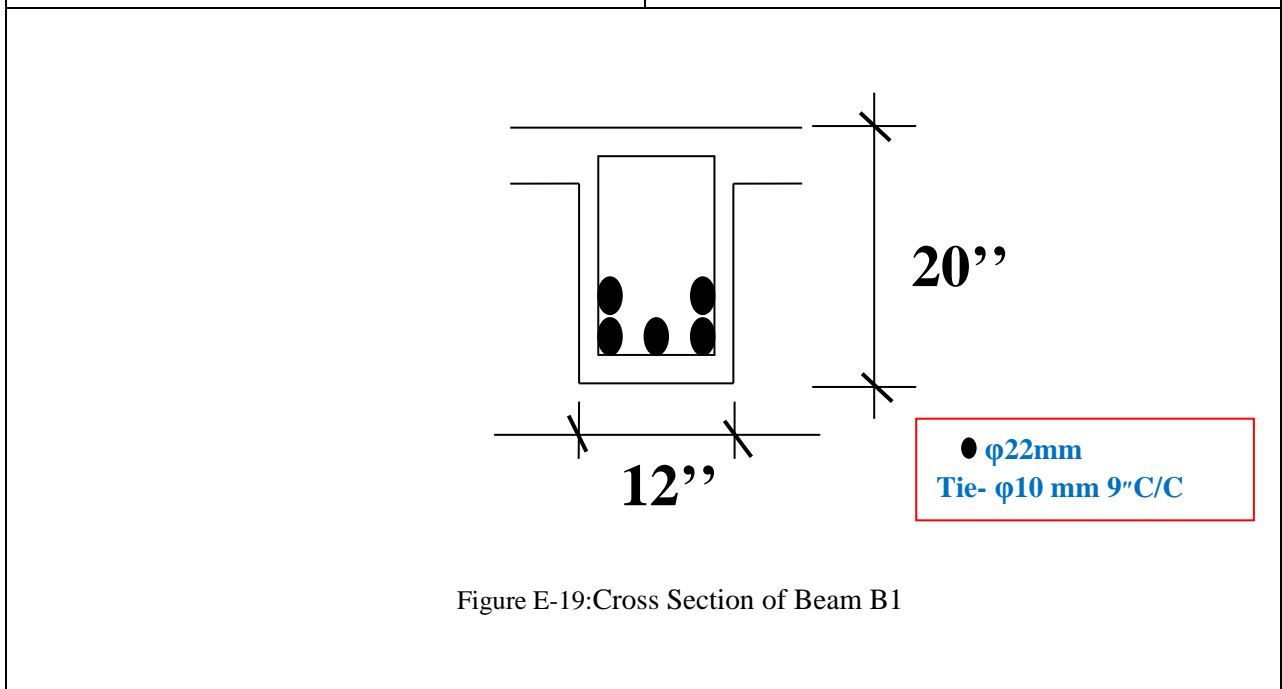

Figure E-19: Cross Section of Beam B1

Figure E-20 is showing the image scan of Slab 1F-S1 of grid AB89. Figure E-21 is showing the cross section of that slab.

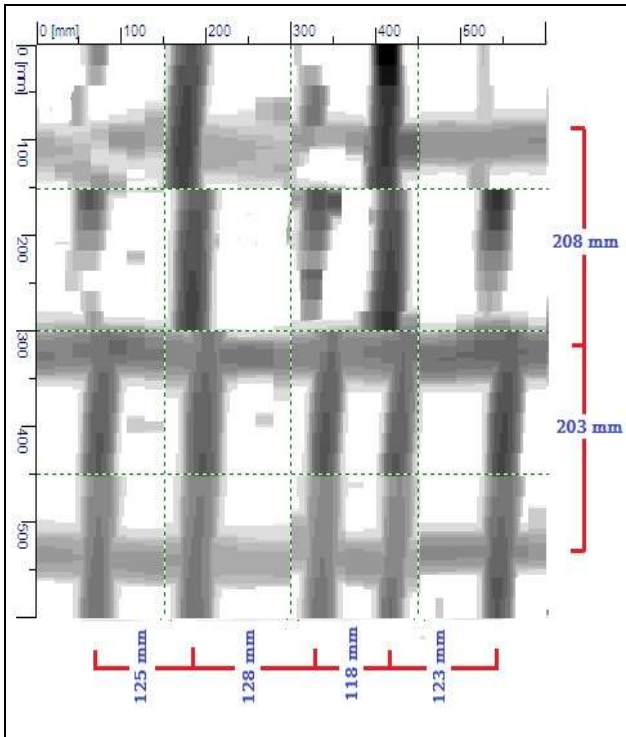

Figure E-20: Image scan of slab 1F-S1

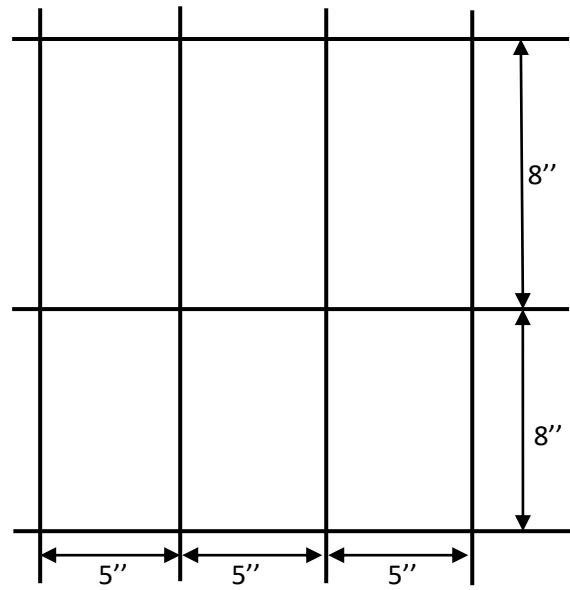

Figure E-21: Cross section of the slab 1F-S1

● $\phi 10\text{mm} @ 8''\text{C/C}$ in long direction &
 $5''\text{C/C}$ in short direction